

— BATH
SOLUTIONS

PRESENTED by

ASD

soluções
de banho





excelência'13



excelência'14

———— ASD
catálogo ———
— *geral* ———
general catalogue —
— catalogue général



www.asd.pt



Na — —ASD

temos consciência que a vida de hoje em dia está repleta de tensões e de stress. Tudo o que ajude a relaxar, a reduzir o stress e a tensão e que produza bem - estar, deve ser considerado como benéfico.

As propriedades curativas da água, eram já conhecidas pelos antigos gregos e romanos e atualmente têm sido redescobertas como uma terapia natural para relaxar tanto o corpo como a mente e para aliviar muitas doenças como a insuficiência sanguínea, a artrose, traumatologias de ordem óssea, muscular ou de ligamentos, stress, celulite e outras.

A gama de produtos ASD inclui modelos e desenhos que se adaptam a todas as necessidades.

Todos os produtos são fabricados com matéria prima da melhor qualidade e estão disponíveis numa variada gama de modelos para satisfazer todos os gostos e decoração.



At — —ASD

we are conscious of stressful is today's life.

Everything able to reduce stress and tension, producing well-being, should be considered as a benefit.

The healing properties of water were largely known by the ancient greek and roman cultures, and are nowadays being rediscovered as a natural therapy, relaxing body and mind and relieving many diseases such as blood insufficiency, degenerative osteoarthritis, muscular, ligaments and bones traumatology, as well stress handling, cellulite reduction, and other.

ASD's products includes models and designs which are easily adapted to all sorts of needs.

All products are manufactured using top quality materials, and are available in a varied range of models to satisfy all tastes and decorations.



Dans — —ASD



nous sommes conscients de la vie stressante d'aujourd'hui.

Tout ce qui aide à se détendre, réduire le stress et les tensions et produit le bien - être, doit être considérée comme bénéfique.

Les propriétés curatives de l'eau ont été largement connue par les cultures antiques grecs et romains, et sont aujourd'hui d'être redécouverte comme une thérapie naturelle pour détendre le corps et l'esprit et soulager de nombreuses maladies comme l'insuffisance artérielle, l'arthrose, le traumatisme d' musculé, des ligaments et des os, le stress, la réduction de la cellulite, et autres.

Produits ASD comprennent des modèles et des conceptions qui sont facilement adaptables à toutes sortes de besoins.

Tous les produits sont fabriqués en utilisant des matériaux de la meilleure qualité et sont disponibles dans une gamme variée de modèles pour satisfaire tous les goûts et décorations.



BANHEIRAS BATHTUBS BAIGNOIRES	04-37
PAINÉIS PANELS PANNEAUX	38-43
ACESSÓRIOS EM MADEIRA WOOD ACCESSORIES ACCESSOIRES EN BOIS	44-45
TORNEIRAS E ACESSÓRIOS BATH DECK MIXER MITIGEUR	46-48
CADEIA DE LEDS LED SPA LIGHTS CHAINE DE LED SPA	49
BASES DE DUCHE SHOWER TRAY RECEVEUR DE DOUCHE	50-87
COLUNAS DE HIDROMASSAGEM HYDROMASSAGE COLUMNS COLONNES DE HYDROMASSAGE	88-109
CABINES DE HIDROMASSAGEM HYDROMASSAGE CABINS CABINES DE HYDROMASSAGE	110-119
RESGUARDOS DE DUCHE SHOWER SCREEN PARE-DOUCHES	120-167
MÓVEIS DE CASA DE BANHO BATHROOM FURNITURE MEUBLES DE SALLE DE BAIN	168-187
LAVATÓRIOS DE ENCASTRAR BASIN TO BUILT-IN LAVABO À ENCASTRÉE	188
LAVATÓRIOS DE POUSAR BASIN A TREND LAVABOS À POSER	189
TORNEIRAS SINGLE-LEVER MIXER MITIGEURS	190-197
CONJUNTOS DE DUCHE SHOWER SETS ENSEMBLES DE DOUCHE	198-199
COLUNAS DE DUCHE SHOWER COLUMN COLONNE DE DOUCHE	200-201
TOALHEIROS TOWEL RAILS PORTE-SERVIETTES	202-205
HIDROMASSAGEM WHIRPOOL HYDROMASSAGE	206
CROMOTERAPIA CHROMOTHERAPY CHROMOTHÉRAPIE	214-215



Joaquim Camarinha
ARQ.



CHARME CANTO

1500x1500
info p.35/p.254



Banheira Planíssima de canto equipada com sistema de hidromassagem eletrônico flat em latão cromado, com opção 7 microjatos;
 Almofadas em poliuretano integral skin preto;
 Conjunto torneira Planíssima;
 Painel frontal madeira 1900x500 lacado especial kourois preto;
 Painel lateral madeira 700x500 lacado especial kourois preto;
 Degrau parcial madeira lacado especial kourois preto;
 Bloco gavetas madeira 550x700x500 lacado especial kourois preto, com 2 gavetas lacadas preto brilhante.

Corner bathtub Planíssima equipped with flat electronic whirlpool system in chromed brass, 7 micro jets optional;
 Headrests in black integral skin polyurethane;
 Planíssima bath deck mixer;
 Front panel, wood 1900x500 special lacquered black kourois;
 Side panel, wood 700x500 special lacquered black kourois;
 Partial step, wood special lacquered black kourois;
 Drawer unit, wood 550x700x500 special lacquered black kourois with 2 drawers lacquered black high gloss.

Baignoire Planíssima coin équipé d'un système de hydromassage électronique flat en laiton chrome, avec l'option 7 microjets;
 Répose-tête polyurethane skin intégrale noir;
 Mitigeur de baignoire d'encastrement Planíssima;
 Tablier frontal en bois 1900x500 laque spécial kourois noir;
 Tablier latéral en bois 700x500 laque spécial kourois noir;
 Étape partielle en bois laque spécial kourois noir;
 Unité de tiroirs en bois 550x700x500 laque spécial kourois noir avec 2 tiroirs laque noir brillant.



PLANÍSSIMA CANTO

DIREITA RIGHT DROITE
1800x1300x700
info p.33/p.243



Banheira Planíssima de canto equipada com sistema de hidromassagem eletrônico flat em latão cromado, com opção 7 microjatos;
Conjunto torneira Planíssima;
Painel frontal madeira 1900x500 lacado especial kouros preto;
Painel lateral madeira 700x500 lacado especial kouros preto;
Degrau integral madeira lacado especial kouros preto.

Corner bathtub Planíssima equipped with flat electronic whirlpool system in chromed brass, 7 micro jets optional;
Planíssima bath deck mixer;
Front panel, wood 1900x500 special lacquered black kouros;
Side panel, wood 700x500 special lacquered black kouros;
Integral step, wood special lacquered black kouros.

Baignoire Planíssima coin équipé d'un système de hydromassage électronique flat en laiton chrome, avec l'option 7 microjets;
Mitigeur de baignoire d'encastrer Planíssima;
Tablier frontal en bois 1900x500 laque spécial kouros noir;
Tablier latéral en bois 700x500 laque spécial kouros noir;
Étape intégral en bois laque spécial kouros noir.



PLANÍSSIMA CANTO

ESQUERDA LEFT GAUCHE

1800x1300x700

info p.32/p.243

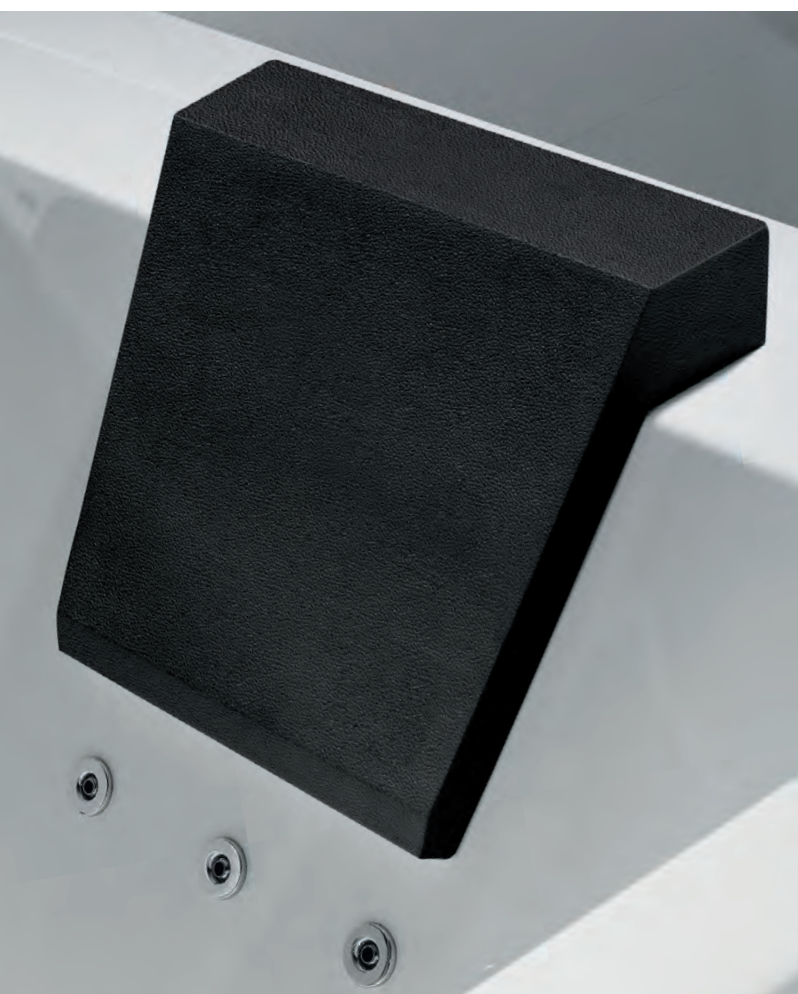

Banheira Planíssima Duo equipada com sistema de hidromassagem comfort em latão cromado, com opção de 6 microjatos; Almofadas em poliuretano integral skin preto; Conjunto de torneira Planíssima.

Bathtub Planíssima Duo equipped with comfort whirlpool system in chromed brass, 6 micro jets optional; Headrests in black integral skin polyurethane; Planíssima bath deck mixer.

Baignoire Planíssima Duo équipé d'un système de hydromassage électronique confort en laiton chrome, avec l'option 6 microjets; Repose-tête polyuréthane skin intégrale noir; Mitigeur de baignoire d'encastrer Planíssima.



◀ 10
▼ 11

PLANÍSSIMA DUO

1900x900
info p.32/p.238



Banheira Planíssima equipada com sistema de hidromassagem eletrônico duplo ABS cromado;
Almofada em poliuretano integral skin preto;
Painel frontal madeira 1800x500 wengué;
Painel lateral madeira 800x500 wengué.

Bathtub Planíssima equipped with electronic double whirlpool system, chromed ABS;
Headrest in black integral skin polyurethane;
Front panel, wengué wood 1800x500;
Side panel, wengué wood 800x500.

Baignoire Planíssima équipé d'un système de hydromassage électronique double en ABS chrome;
Repose-tête polyuréthane skin intégrale noir;
Tablier frontal en bois 1800x500 wengué;
Tablier latéral en bois 800x500 wengué.



PLANÍSSIMA

1800x800
info p.32/p.228



Banheira Charme equipada com sistema de hidromassagem eletrônico kombi em abs cromado, com opção 7 microjatos;

Painel frontal madeira 1800x500 lacado vermelho rubi brilhante;

Painel lateral madeira 800x500 lacado vermelho rubi brilhante;

Bloco de gavetas em madeira com rodas, com 2 gavetas, 450x580x420, lacado vermelho rubi brilhante.

Bathtub Charme equipped with kombi electronic whirlpool system in chromed abs, 7 micro jets optional;

Front panel, wood 1800x500 lacquered red ruby high gloss;

Side panel, wood 800x500 lacquered red ruby high gloss;

Drawer unit in wood with wheels and 2 drawers, 450x580x420, lacquered red ruby high gloss.

Baignoire Charme équipé d'un système de hydromassage électronique kombi en abs chrome, avec l'option 7 microjets;

Tablier frontal en bois 1800x500 laque rouge rubis brillant;

Tablier latéral en bois 800x500 laque rouge rubis brillant;

Unité de tiroirs en bois avec roues et 2 tiroirs, 450x580x420, laque brillant rouge rubis.



CHARME

1800x800
info p.33/p.247



Banheira Clássica-Duo equipada com sistema de hidromassagem pneumático simples ABS cromado com opção 6 microjatos;
 Painel frontal acrílico branco 1900x500;
 Painel lateral direito acrílico branco 900x500.

Bathtub Clássica-Duo equipped with pneumatic simple whirlpool system in chromed ABS, 6 micro jets optional;
 Front acrylic panel in white 1900x500;
 Right side acrylic panel in white 900x500.

Baignoire Clássica-Duo équipé d'un système de hydromassage pneumatique simple chrome abs avec l'option 6 microjet;
 Tablier frontal en acrylique blanc 1900x500;
 Tablier latéral droit en acrylique blanc 900x500.



CLÁSSICA DUO

1900x900
info p.33/p.227



Banheira Clássica equipada com sistema de hidromassagem eletrónico simples abs cromado, com opção 7 microjatos;
Almofada em poliuretano integral skin preto;
Painel frontal madeira 1700x500 faia;
Painel lateral madeira 800x500 faia;
Par de pegas cromadas.

Bathtub Clássica equipada with electronic simple whirlpool system in chromed abs, 7 micro jets optional;
Headrest in black integral skin polyurethane;
Front panel, beech wood 1700x500;
Side panel, beech wood 800x500;
Pair of chromed handles.

Baignoire Clássica équipé d'un système de hydromassage électronique simple en abs chrome, avec l'option 7 microjets;
Repose-tête polyuréthane skin intégrale noir;
Tablier frontal en bois 1700x500 hêtre;
Tablier latéral en bois 800x500 hêtre;
Paire de poignées chromées.



CLÁSSICA

1700x800
info p.34/p.219



Banheira Charme de canto equipada com sistema de hidromassagem eletrônico flat em latão cromado, com opção 7 microjatos, sistema de desinfecção automática e lâmpada de iodo;
Almofada em poliuretano integral skin preto;
Conjunto torneira Extraplana;
Painel acrílico branco 1500x500.

Corner bathtub Charme equipped with flat electronic whirlpool system in chromed brass, 7 micro jets, automatic disinfection system and spa light optional;
Headrest in black integral skin polyurethane;
Extraplana bath deck mixer;
White acrylic panel 1500x500.

Baignoire Charme coin équipé d'un système de hydromassage électronique flat en laiton chrome, avec l'option 7 microjets, système de désinfection automatique et lumière;
Repose-tête polyurethane skin intégrale noir;
Mitigeur de baignoire d'encastrer Extraplana;
Panneau acrylique blanc 1500x500.



CHARME CANTO

1500x1500
info p.35/p.254



Banheira Elegance equipada com sistema de hidromassagem electrónico duplo ABS cromado, com opção 6 microjactos. Painel acrílico branco com degrau 1500x550 (também disponível sem degrau).

Bathtub Elegance equipped with electronic double whirlpool system in chromed ABS, 6 micro jets. White acrylic panel with step, 1500x550 (also available without step).

Baignoire Tilia équipée avec double whirlpool électronique chrome ABS. Alternativement jets d'eau ont été remplacés par 24 microjets. Panneau acrylique blanc à l'étape, 1500x550 (également disponible sans étape).



ELEGANCE

1500x1500
info p.35/p.261



Banheira Tilia equipada com sistema hidromassagem eletrônico duplo ABS cromado. Como opção os jactos de água foram substituídos por 24 microjactos. Painel acrílico branco 1450x550 (também disponível com degrau).

Bathtub Tilia equipped with electronic double whirlpool system chromed ABS. Optionally, the water jets were replaced by 24 micro jets. White acrylic panel, 1450x550 (also available with step).

Baignoire Tilia équipée avec double whirlpool électronique chrome ABS. Alternativement jets d'eau ont été remplacés par 24 microjets. Panneau acrylique blanc 1450x550 (Egalement disponible à l'étape).



TÍLIA
1450x1450
info p.35/p.260



Banheira Tulipa equipada com sistema de hidromassagem electrónico duplo ABS, cromado com opção 6 microjactos e sistema de desinfeção automática. Painel acrílico branco 1400x550.

Bathtub Tulipa equipped with electronic double whirlpool system in chromed ABS, 6 micro jets and automatic disinfection system optional. White acrylic panel 1400x550.

Baignoire Tulipa équipé d'un système de hydromassage électronique double en ABS chrome, avec l'option 6 microjets et système de désinfection automatique. Panneau acrylique blanc 1400x550.



TULIPA

1400x1400
info p.36/p.259



Banheira Gardénia de canto equipada com sistema de hidromassagem eletrônico simples ABS, com opção 7 microjatos;
Monocomando banheira Quadra com bica, inversor, chuveiro de mão, suporte e flexível;
Painel acrílico branco 1200x500.

Corner bathtub Gardénia equipped with electronic simple whirlpool system in chromed ABS, 7 micro jets optional;
Bath mixer with spout, diverter, handshower, flexible and support;
White acrylic panel 1200x500.

Baignoire Gardénia coin équipé d'un système de hydromassage électronique simple en ABS chrome, avec l'option 7 microjets;
Mitigeur bain mural avec bec, inverseur, douchette, flexible et support;
Panneau acrylique blanc 1200x500.



GARDÉNIA CANTO

1200x1200
info p.37/p.253



Banheira Camélia Direita equipada com sistema de hidromassagem pneumático duplo ABS cromado, com opção 7 microjactos. Painel acrílico branco direito 1580x500.

Bathtub Camélia Right equipped with pneumatic double whirlpool system in chromed ABS, 7 micro jets optional. Right white acrylic panel 1580x500.

Baignoire Camélia Droite équipé avec double pneumatique chrome système tourbillon ABS avec option 7 microjets. Panneau acrylique blanc droite 1580x500.





CAMÉLIA

DIREITA/ ESQUERDA RIGHT/LEFT DROITE/GAUCHE

1580x1030

info p.36-37/p.262



BANHEIRAS

BATH TUBS
BAIGNOIRES

PLANÍSSIMA CANTO p.08/p.243-246

ESQUERDA | LEFT | GAUCHE



A	B	C
1800	1300	700
1700	1200	650
1700	1000	650
1600	1000	650

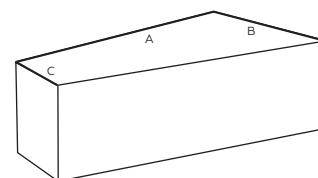

PLANÍSSIMA DUO p.10/p.238-242



A	B
2000	1000*
1900	900*
1900	800
1800	900
1800	800

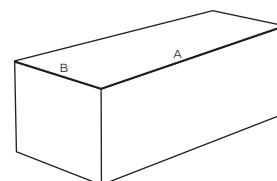

PLANÍSSIMA p.12/p.228-241



A	B
1900	1000*
1900	900*
1800	800
1800	750
1700	800
1700	750
1700	700
1600	750
1600	700
1500	700

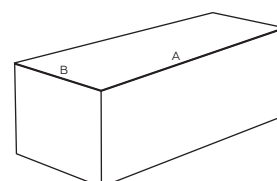

PNEUMÁTICO SIMPLÉS ABS
SIMPLE PNEUMATIC ABS
PNEUMATIQUE SIMPLE ABS



PNEUMÁTICO DUPLO ABS
DOUBLE PNEUMATIC ABS
PNEUMATIQUE DOBLE ABS



ELETRÓNICO SIMPLÉS ABS
SIMPLE ELECTRONIC ABS
ELECTRONIQUE SIMPLE ABS



p.06/p.243-246 **PLANÍSSIMA CANTO**
DIREITA | RIGHT | DROITE

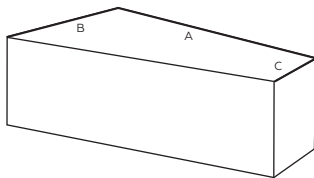

A	B	C
1800	1300	700
1700	1200	650
1700	1000	650
1600	1000	650



p.14/p.247-252 **CHARME**

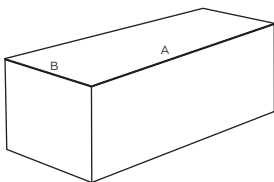

A	B
1800	800
1700	800
1700	750
1700	700
1600	750
1600	700



p.16/p.227 **CLÁSSICA DUO**

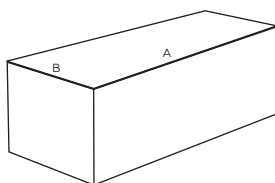

A	B
1900	900





BANHEIRAS

BATH TUBS
BAIGNOIRES

CLÁSSICA p.18/p.221-226



A	B
1800	800
1700	800
1700	750
1700	700
1600	750
1600	700

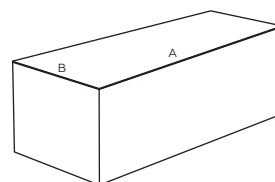

CLÁSSICA p.18/p.218-220



A	B
1500	700*
1400	700*
1350	700

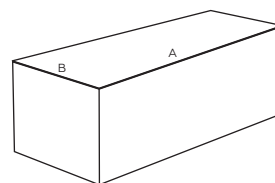

CLÁSSICA p.218



A	B
1200	700

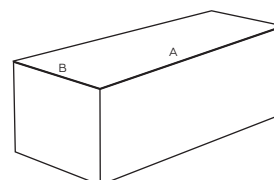



p.20/p.254-258 CHARME CANTO

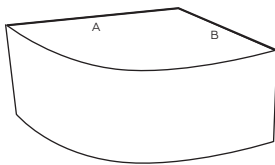

A	B
1500	1500
1450	1450
1400	1400
1350	1350
1300	1300



P.22/p.261 ELEGANCE

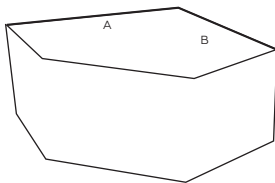

A	B
1500	1500



p.24/p.260 TILIA

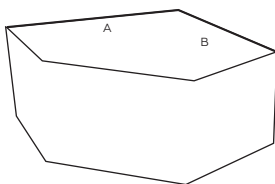

A	B
1450	1450





BANHEIRAS

BATH TUBS
BAIGNOIRES

CAMÉLIA p.30/p.262
ESQUERDA | LEFT | GAUCHE

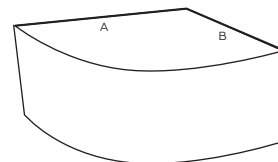

A B
1580 1030



TULIPA p.26/p.259

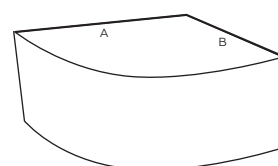

A B
1400 1400





p.30/p.262 CAMÉLIA
DIREITA | RIGHT | DROITE

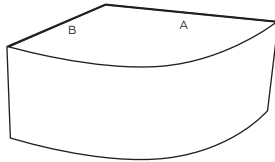

A B
1580 1030



p.28/p.253 GARDÉNIA CANTO

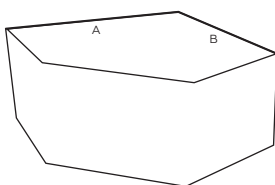

A B
1200 1200





PAINÉIS EM ACRÍLICO

ACRYLIC PANELS
PANNEAUX EN ACRYLIQUE

FRONTAL E LATERAL p.260 FRONTAL AND LATERAL | FRONTAL ET LATÉRAL

Acabamento acrílico branco
Finished: white acrylic | Finition: blanc acrylique



A	B
1200	500
1350	500
1400	500
1500	500
1600	500
1700	500
1800	500
1900	500
2000	500

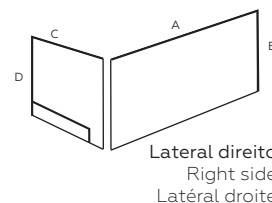

C	D
700	500
750	500
800	500
900	500
1000	500

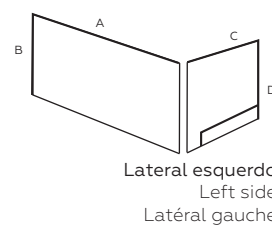

CHARME CANTO p.20/p.266

Acabamento acrílico branco
Finished: white acrylic | Finition: blanc acrylique



A	B
1500	500
1450	500
1400	500
1350	500
1300	500

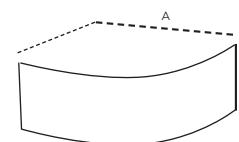



p.22/p.266 **CANTO COM DEGRAU**
CORNER WITH STEP | D'ANGLE AVEC L'ETAPE

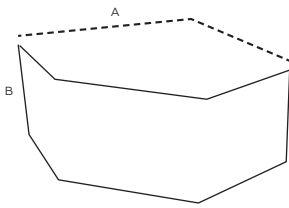

A	B
1500	550
1450	550



p.24/p.266 **CANTO SEM DEGRAU**
CORNER WITHOUT STEP | D'ANGLE SANS L'ETAPE

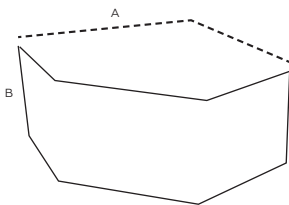

A	B
1500	550
1450	550



p.26/p.266 **TULIPA**

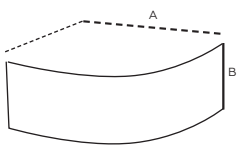

A	B
1400	550





PAINÉIS EM ACRÍLICO

ACRYLIC PANELS
PANNEAUX EN ACRYLIQUE

CAMÉLIA p.30/p.266 ESQUERDA | LEFT | GAUCHE



A B
1580 500

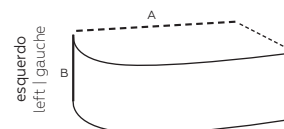

CAMÉLIA p.30/p.266 DIREITA | RIGHT | DROITE



A B
1580 500

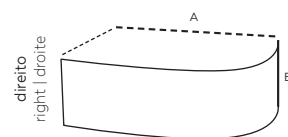

GARDÉNIA p.28/p.266



A B
1200 500

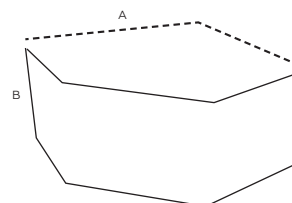

PAINÉIS EM FENÓLICO

PHENOLIC PANELS
PANNEAUX EN PHÉNOLIQUE



Acabamento: fenólico castanho

Finished: phenolic brown | Finition: phénolique marrón

p.267 CASTANHO
BROWN | MARRÓN

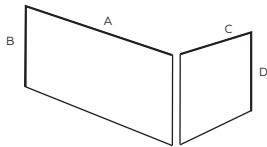

A	B	C	D
1200	500	700	500
1350	500	750	500
1400	500	800	500
1500	500	900	500
1600	500	1000	500
1700	500		
1800	500		
1900	500		
2000	500		



Acabamento: fenólico faia

Finished: phenolic brown | Finition: phénolique marrón

p.267 FAIA
BEECH | HÊTRE

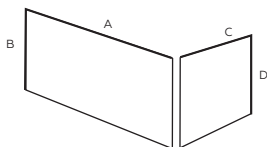

A	B	C	D
1200	500	700	500
1350	500	750	500
1400	500	800	500
1500	500	900	500
1600	500	1000	500
1700	500		
1800	500		
1900	500		
2000	500		



Acabamento: fenólico mel

Finished: phenolic honey | Finition: phénolique miel

p.267 MEL
HONEY | MIEL

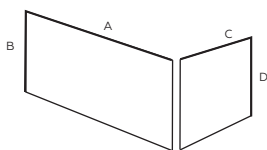

A	B	C	D
1200	500	700	500
1350	500	750	500
1400	500	800	500
1500	500	900	500
1600	500	1000	500
1700	500		
1800	500		
1900	500		
2000	500		



Acabamento: fenólico wengué

Finished: phenolic wengué | Finition: phénolique wengué

p.267 WENGUÉ
WENGUÉ | WENGUÉ

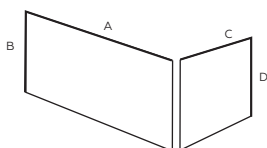

A	B	C	D
1200	500	700	500
1350	500	750	500
1400	500	800	500
1500	500	900	500
1600	500	1000	500
1700	500		
1800	500		
1900	500		
2000	500		





PAINÉIS LACADOS

LACQUERED PANELS
PANNEAUX LAQUÉ

MADEIRA - VERDE p.267 WOOD - GREEN | BOIS - VERT

Acabamento: lacado verde brilhante
Finished: green high gloss lacquered | Finition: laqué en vert brillant



A	B	C	D
1200	500	700	500
1350	500	750	500
1400	500	800	500
1500	500	900	500
1600	500	1000	500
1700	500		
1800	500		
1900	500		
2000	500		

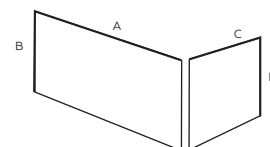

MADEIRA - LARANJA p.267 WOOD - ORANGE | BOIS - L'ORANGE

Acabamento: lacado laranja brilhante
Finished: orange high gloss lacquered | Finition: laqué en l'orange brillant



A	B	C	D
1200	500	700	500
1350	500	750	500
1400	500	800	500
1500	500	900	500
1600	500	1000	500
1700	500		
1800	500		
1900	500		
2000	500		

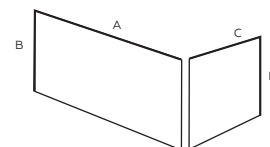

MADEIRA - VIOLETA p.267 WOOD - VIOLET | BOIS - VIOLET

Acabamento: lacado violeta brilhante
Finished: violet high gloss lacquered | Finition: laqué en violet brillant



A	B	C	D
1200	500	700	500
1350	500	750	500
1400	500	800	500
1500	500	900	500
1600	500	1000	500
1700	500		
1800	500		
1900	500		
2000	500		

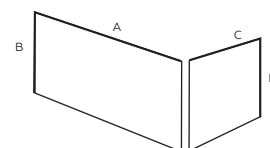

Acabamento: lacado rubi brilhante
 Finished: ruby high gloss lacquered | Finition: laqué en rubis brillant

p.267 MADEIRA - RUBI
 WOOD - RUBY | BOIS - RUBIS

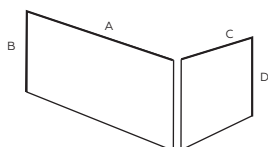

A	B	C	D
1200	500	700	500
1350	500	750	500
1400	500	800	500
1500	500	900	500
1600	500	1000	500
1700	500		
1800	500		
1900	500		
2000	500		



Acabamento: lacado grafite brilhante
 Finished: graphit high gloss lacquered | Finition: laqué en graphite brillant

p.267 MADEIRA - GRAFITE
 WOOD - GRAPHIT | BOIS - GRAPHITE

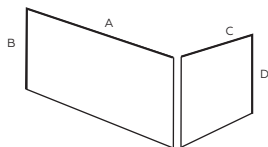

A	B	C	D
1200	500	700	500
1350	500	750	500
1400	500	800	500
1500	500	900	500
1600	500	1000	500
1700	500		
1800	500		
1900	500		
2000	500		



Acabamento: lacado preto brilhante
 Finished: black high gloss lacquered | Finition: laqué en noir brillant

p.267 MADEIRA - PRETO
 WOOD - BLACK | BOIS - NOIR

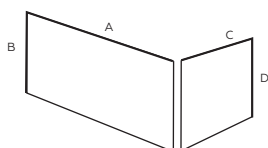

A	B	C	D
1200	500	700	500
1350	500	750	500
1400	500	800	500
1500	500	900	500
1600	500	1000	500
1700	500		
1800	500		
1900	500		
2000	500		





ACESSÓRIOS EM MADEIRA

WOOD ACCESSORIES
ACCESSOIRES EN BOIS

CONJUNTO PAINÉIS PLANÍSSIMA DE CANTO p.06-09/p.243-246 SET PANELS FOR PLANÍSSIMA CORNER ENSEMBLE DE PANNEAUX POUR PLANÍSSIMA D'ANGLE

Acabamento: envernizado, lacado e kouros
Finished: varnished, lacquered and kouros
Finition: verni, laqué et kouros



A	B
1700	500
1800	500

A	B
650	500
700	500

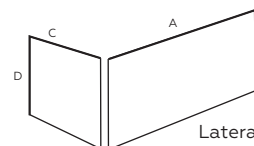

Lateral direito
Right side
Latéral droite

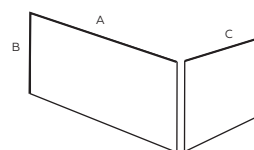

Lateral esquerdo
Left side
Latéral gauche

DEGRAU INTEGRAL DE MADEIRA p.08/p.243-246 INTEGRAL WOOD STEP ÉTAPE INTEGRALE EN BOIS

Acabamento: envernizado, lacado e kouros
Finished: varnished, lacquered and kouros
Finition: verni, laqué et kouros



A	B	C	D
1700	200	1796	550
1800	200	1896	600

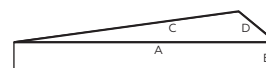

DEGRAU PARCIAL DE MADEIRA p.06/p.243-246 PARTIAL WOOD STEP ÉTAPE PARTIELLE EN BOIS

Acabamento: envernizado, lacado e kouros
Finished: varnished, lacquered and kouros
Finition: verni, laqué et kouros



A	B	C	D
1090	200	1145	350

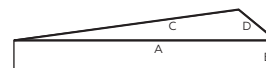

Acabamento: envernizado, lacado e kouros
 Finished: varnished, lacquered and kouros
 Finition: verni, laqué et kouros

p.06/p.243-246/p.267 **MÓDULO GAVETAS PLANÍSSIMA**
 PLANÍSSIMA DRAWER UNIT
 UNITÉ DE TIROIRS PLANÍSSIMA

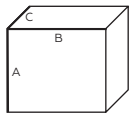

A	B	C
550	500	650
550	500	700



Acabamento: envernizado, lacado e kouros
 Finished: varnished, lacquered and kouros
 Finition: verni, laqué et kouros

p.14/p.267 **MÓDULO GAVETAS COM 4 RODAS**
 DRAWER UNIT WITH 4 WHEELS
 UNITÉ DE TIROIRS AVEC 4 ROUES

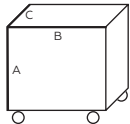

A	B	C
450	580	420
580	800	420



OUTROS ACABAMENTOS PARA PAINÉIS MADEIRA E MÓDULOS DE GAVETAS
 OTHER FINISH TO WOOD PANELS AND MODULE DRAWERS
 D'AUTRES FINITIONS POUR PANNEAUX DE BOIS ET MODULE DE TIROIRS

KOUROS Branco
 KOUROS White
 KOUROS Blanc

KOUROS Preto
 KOUROS Black
 KOUROS Noir

KOUROS Vermelho
 KOUROS Red
 KOUROS Rouge

KOUROS Savana
 KOUROS Savannah
 KOUROS Savane

KOUROS Camel
 KOUROS Camel
 KOUROS Chamelle

Madeira Zebrano
 Zebrano Wood
 Bois Zebrano





TORNEIRAS E ACESSÓRIOS p.264

BATH DECK MIXER AND ACCESSORIES
MITIGEUR D'ENCASTRÉ ET ACCESSOIRES

CONJUNTO TORNEIRA PLANÍSSIMA
PLANÍSSIMA BATH DECK MIXER
MITIGEUR DE BAIGNOIRE D'ENCASTRER PLANÍSSIMA



CONJUNTO TORNEIRA EXTRAPLANA
EXTRAPLANA BATH DECK MIXER
MITIGEUR DE BAIGNOIRE D'ENCASTRER EXTRAPLANA



CONJUNTO TORNEIRA NASCENTE
NASCENTE BATH DECK MIXER
MITIGEUR DE BAIGNOIRE D'ENCASTRER NASCENTE



CONJUNTO TORNEIRA QUADRA
QUADRA BATH DECK MIXER
MITIGEUR DE BAIGNOIRE D'ENCASTRER QUADRA



CONJUNTO TORNEIRA CILÍNDRICA
CILÍNDRICA BATH DECK MIXER
MITIGEUR DE BAIGNOIRE D'ENCASTRER CILÍNDRICA



CONJUNTO CASCATA DE ENCASTRAR
CASCATA BUILT-IN SET
ENSEMBLE D'ENCASTRER CASCATA



CONJUNTO ENCHIMENTO POR VÁLVULA QUADRA

QUADRA WATER OUTLET SET THROUGH BATH POP-UP WASTE
ENSEMBLE DE REMPLISSAGE D'EAU PAR LE VIDAGE AUTOMATIQUE QUADRA



CONJUNTO ENCHIMENTO POR VÁLVULA CILÍNDRICA

CILÍNDRICA WATER OUTLET SET THROUGH BATH POP-UP WASTE
ENSEMBLE DE REMPLISSAGE D'EAU PAR LE VIDAGE AUTOMATIQUE QUADRA



MONOCOMANDO DE BANHEIRA AO CHÃO QUADRA

SINGLE-LEVER MIXER TO FLOOR QUADRA
MITIGEUR DE BAIGNOIRE AU SOL QUADRA



MONOCOMANDO DE BANHEIRA AO CHÃO CILÍNDRICA

SINGLE-LEVER MIXER TO FLOOR CILÍNDRICA
MITIGEUR DE BAIGNOIRE AU SOL CILÍNDRICA



VÁLVULA AUTOMÁTICA PARA BANHEIRA

AUTOMATIC POP-UP WASTE FOR BATHTUB
VIDAGE AUTOMATIQUE POUR BAIGNOIRE



CONJUNTO ANTI-GOTAS PARA TORNEIRA DE ENCASTRAR

ANTI-DROPS SET FOR BATH DECK MIXER
ANTI-GOUTTES ASSEMBLE POUR MITIGEUR D'ENCASTRER





ACESSÓRIOS p.265

ACCESSORIES
ACCESSOIRES

PEGAS PARA CLÁSSICA DUO
HANDLES FOR CLÁSSICA DUO
POIGNÉES POUR CLÁSSICA DUO



PEGAS PARA CHARME E CLÁSSICA
HANDLES FOR CHARME AND CLÁSSICA
POIGNÉES POUR CHARME ET CLÁSSICA



ALMOFADA PRETA PARA PLANÍSSIMA
BLACK HEADREST FOR PLANÍSSIMA
REPOSE-TÊTE NOIR POUR PLANÍSSIMA

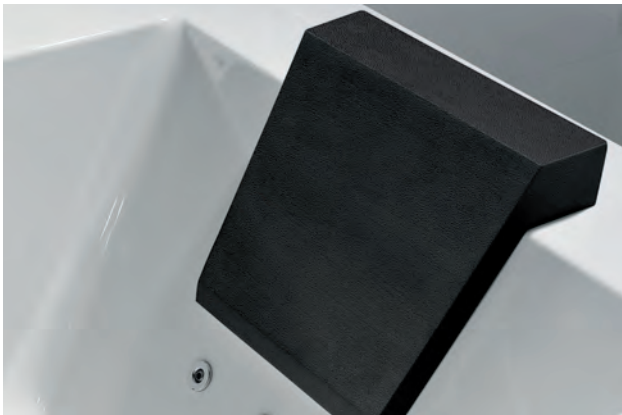

ALMOFADA PRETA PARA CLÁSSICA
BLACK HEADREST FOR CLÁSSICA
REPOSE-TÊTE NOIR POUR CLÁSSICA



ALMOFADA PRETA PARA CHARME
BLACK HEADREST FOR CHARME
REPOSE-TÊTE NOIR POUR CHARME

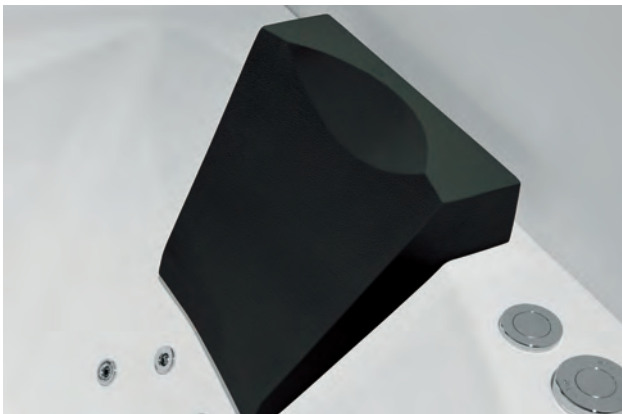



BRANCO
WHITE | BLANC

EFEITO CADEIA DE LUZ – LINHA FLAT

EFFECT LIGHT CHAIN - FLATLINE | EFFET CHAÎNE LÉGÈRE – FLATLINE

Para instalação em banheiras simples ou de hidromassagem;
Terapia de luz que alterna suavemente entre 7 cores;
Tecnologia totalmente segura – leds impermeáveis.

For the installation in bathtubs or whirlpools;
Color-light therapy with 7 gently alternating colors;
Totally safe technology - leds waterproof.

Pour l'installation dans les baignoires simple ou avec hydromassage;
La luminothérapie qui bascule doucement entre 7 couleurs;
Technologie totalement sûr - leds imperméable à l'eau.



MARINHO
NAVY BLUE | BLEU MARINE



AMARELO
YELLOW | JAUNE



AZUL
BLUE | BLEU



VERDE
GREEN | VERT



VERMELHO
RED | ROUGE



VIOLETA
VIOLET | VIOLET



Base de duche acrílica Easyhelp 25 preparada para encastrar ao nivel do piso;
Aba 10mm;
Altura interior (cuba) 25mm;
Fundo liso;
Válvula de descarga sifonada SLIM de ø90mm incluída.

Acrylic Easyhelp 25 showertray prepared for installation at floor level;
Panel 10mm;
Interior height 25mm;
Smooth bottom;
Outlet drain slim with waste hole 90mm included.

Receveur de douche acrylique Easyhelp 25 préparé pour l'installation au niveau du sol;
Panel 10mm;
Hauteur intérieure 25mm;
Fond lisse;
Bonde de douche siphonné slim 90mm avec réservoir inclus.



EASYHELP 25

ENCASTRAR

1200x800
info p.74/p.268-269



Base de duche acrílica Easyhelp 45 preparada para encastrar ao nivel do piso;
Aba 10mm;
Altura interior (cuba) 45mm;
Fundo liso;
Válvula de descarga sifonada SLIM de ø90mm incluída.

Acrylic Easyhelp 45 showertray prepared for installation at floor level;
Panel 10mm;
Interior height 45mm;
Smooth bottom;
Outlet drain slim with waste hole 90mm included.

Receveur de douche acrylique Easyhelp 45 préparé pour l'installation au niveau du sol;
Panel 10mm;
Hauteur intérieure 45mm;
Fond lisse;
Bonde de douche siphonné slim 90mm avec réservoir inclus.



EASYHELP 45

ENCASTRAR

1300x900
info p.76/p.270-271

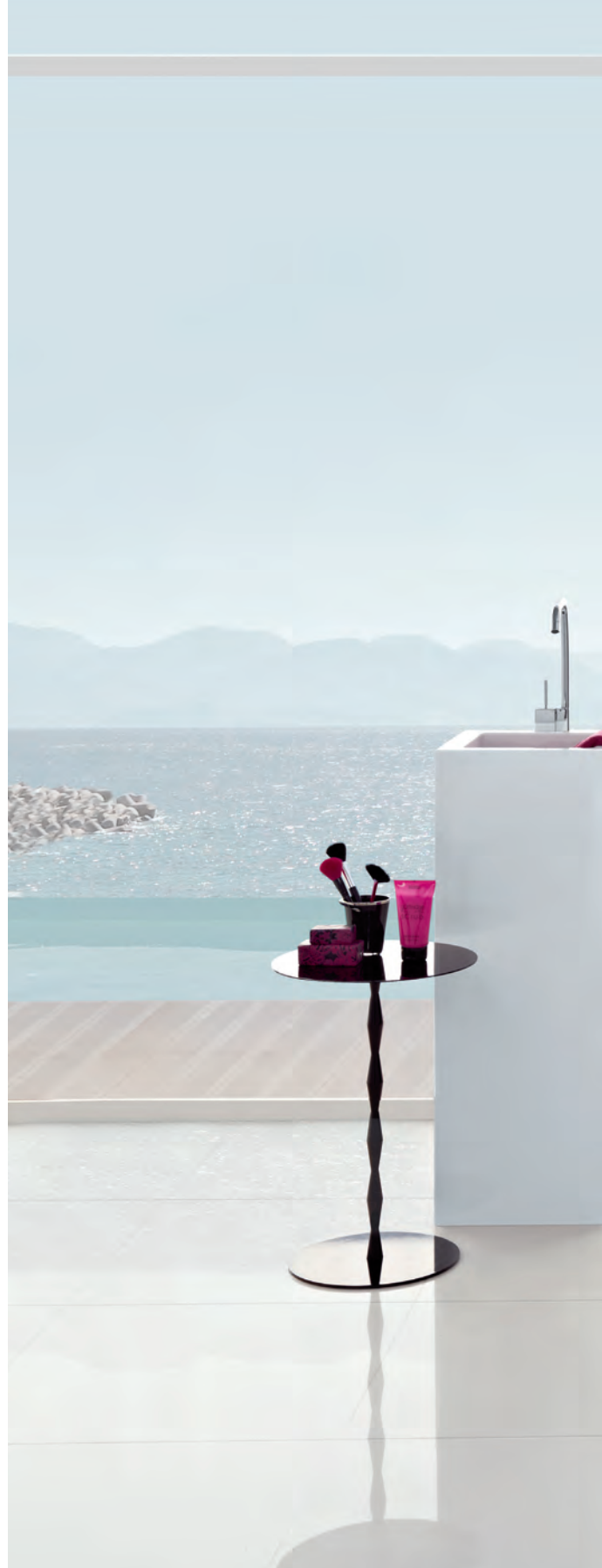

Base de duche acrílica Extraplana com aba integral de 50mm ou 100mm;
 Altura interior (cuba) 25mm;
 Fundo liso;
 Válvula de descarga sifonada SLIM de ø90 incluída;
 Coluna INOX 1830x250x87mm com placa em acrílico preto.

Acrylic Extraplana showertray with 50mm or 100mm integral border;
 Interior height 25mm;
 Smooth bottom;
 Outlet drain slim with waste hole 90mm included;
 Column INOX 1830x250x87mm with black acrylic sheet.

Receveur de douche acrylique Extraplana avec bord intégral de 50mm ou 100mm;
 Hauteur intérieure 25mm;
 Fond lisse;
 Bonde de douche siphoné slim 90mm avec réservoir inclus;
 Colonne INOX 1830x250x87mm avec plaque acrylique noir.



EXTRAPLANA

900x900
info p.78-79/p.272-273



Base de duche acrílica Planíssima com aba integral de 75mm;
Altura interior (cuba) 45mm;
Fundo antiderrapante;
Válvula de descarga sifonada SLIM \varnothing 90 incluída;
Coluna INOX 1530x250x87mm com placa em acrílico branco.

Acrylic Planíssima showertray with 75mm integral border;
Interior height 45mm;
Non-slip bottom;
Outlet drain slim with waste hole 90mm included;
Column INOX 1530x250x87mm with white acrylic sheet.

Receveur de douche acrylique Planíssima avec bord intégral de 75mm;
Hauteur intérieure 45mm;
Fond antiglissant;
Bonde de douche siphoné slim 90mm avec réservoir inclus;
Colonne INOX 1530x250x87mm avec plaque acrylique blanc.



PLANÍSSIMA

ANTIDERRAPANTE 1400x800
info p.80/p.274



Base de duche acrílica Planíssima com aba integral de 75mm;
Altura interior (cuba) 45mm;
Fundo liso;
Válvula de descarga sifonada SLIM ø90 incluída;
Coluna ECO 1830x250x87mm com placa em acrílico branco.

Acrylic Planíssima showertray with 75mm integral border;
Interior height 45mm;
Smooth bottom;
Outlet drain slim with waste hole 90mm included;
Column ECO 1830x250x87mm with white acrylic sheet.

Receveur de douche acrylique Planíssima avec bord intégral de 75mm;
Hauteur intérieure 45mm;
Fond lisse;
Bonde de douche siphoné slim 90mm avec réservoir inclus;
Colonne ECO 1830x250x87mm avec plaque acrylique blanc.



PLANÍSSIMA

1400x800
info p.81/p.274



Base de duche acrílica Planíssima com aba integral de 75mm;
 Altura interior (cuba) 45mm;
 Fundo liso;
 Válvula de descarga sifonada SLIM ø90 incluída;
 Chuveiro quadrado ABS efeito "rain" 200x200x10mm com braço de chuveiro quadrado de parede 25x25x400mm;
 Monocomando 1 via (liga/desliga a água do chuveiro fixo).

Acrylic Planíssima showertray with 75mm integral border;
 Interior height 45mm;
 Smooth bottom;
 Outlet drain slim with waste hole 90mm included;
 Rain-effect" overhead shower square 200x200x10mm with wall shower arm 25x25x400mm;
 Built-in 1 way out shower mixer (on/off water in the fixed shower).

Receveur de douche acrylique Planíssima avec bord intégral de 75mm;
 Hauteur intérieure 45mm;
 Fond lisse;
 Bonde de douche siphoné slim 90mm avec réservoir inclus;
 Pomme de douche ABS carré"effet de pluie" avec bras mural de douche 25x25x400mm;
 Mitigeur bain à encastrer, 1 sortie (allume et éteint l'eau dans la douche fixée).



PLANÍSSIMA

1000x1000
info p.81/p.274



Base de duche acrílica Clássica com aba integral de 75mm;
 Altura interior (cuba) 50mm;
 Antiderrapante;
 Válvula de descarga opcional (não incluída);
 Chuveiro redondo ABS efeito "rain" Ø200x10mm com braço de chuveiro redondo de parede Ø22x400mm;
 Monocomando 1 via (liga/desliga a água do chuveiro fixo).

Acrylic Clássica showertray with 75mm integral border;
 Interior height 50mm;
 Non-slip;
 Outlet drain optional (not included);
 Rain-effect" overhead shower round Ø200x10mm with wall shower arm Ø22x400mm;
 Built-in 1 way out shower mixer (on/off water in the fixed shower).

Receveur de douche acrylique Clássica avec bord intégral de 75mm;
 Hauteur intérieure 50mm;
 Antiglissant;
 Bonde de douche optionnelle (pas inclus);
 Pomme de douche ABS ronde "effet de pluie" avec bras mural de douche Ø22x400mm;
 Mitigeur bain à encastrer, 1 sortie (allume et éteint l'eau dans la douche fixée).



CLÁSSICA

1200x800
info p.83/p.276

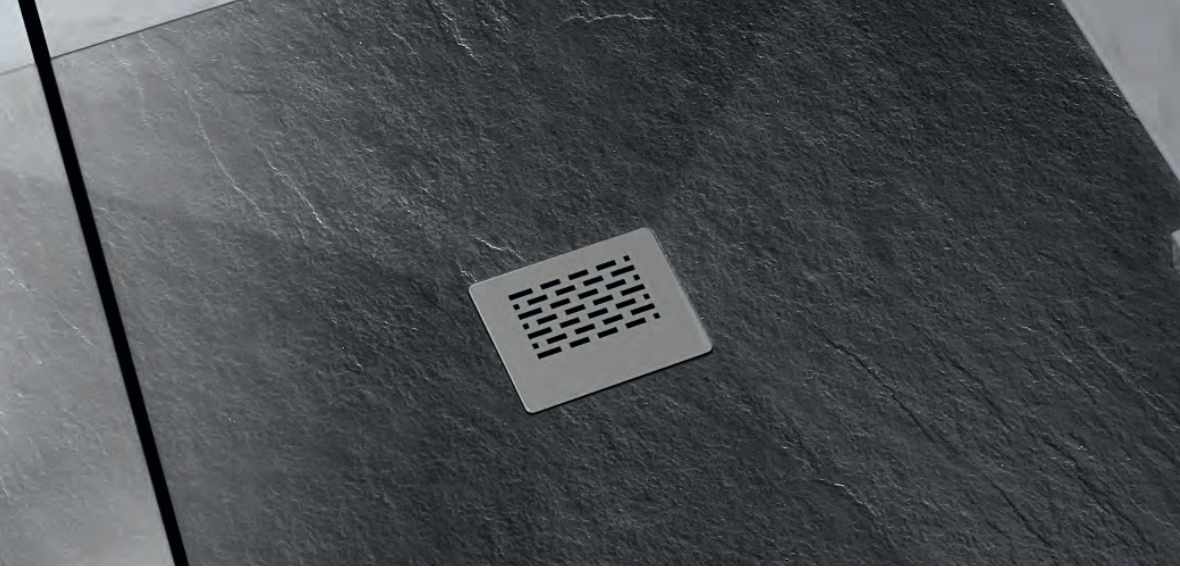

CORES DISPONÍVEIS (por encomenda)
 OUTRAS CORES (sob consulta)
 AVAILABLE COLORS (by order)
 OTHER COLORS (under request)
 COULEURS DISPONIBLES (sur demande)
 AUTRES COULEURS (sur demande)



BRANCO
 WHITE | BLANC

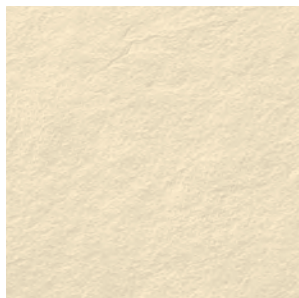

BEGE
 BEIGE | BEIGE



CINZA
 GRAY | GRIS

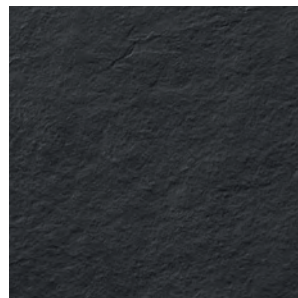

ANTRACITE
 ANTHRACITE | ANTHRACITE



MALVA
 MAUVE | MAUVE



MOKA
 MOKA | MOKA



CHOCOLATE
 CHOCOLATE | CHOCOLATE

Base de duche Planstone antideslizante;
 Material sólido para superfícies, sem poros e homogéneo, composto por resina poliéster, matérias naturais e acabamento em gel coat sanitário;
 Antibactérias;
 Textura de ardósia;
 Válvula de descarga sifonada Ø90 incluída;
 Aba 30mm;
 Grelha quadrada de aço inox 316 com 145mm;
 Possibilidade do cliente cortar à medida.

Anti-slip Planstone showertray;
 Solid material to surfaces without pores and homogeneous, composed of polyester resin, natural materials and finished in gel coat sanitary;
 Antibacterial;
 Slate finish;
 Includes siphoned Ø90 wastpipe;
 30mm high shower tray;
 316 stainless steel grill with 145mm;
 Possibility of customer cut to measure.

Receveur de douche Planstone antidérapant;
 Matériau solide pour surfaces sans pores et homogène, composé d'une résine de polyester, des matériaux naturels et fini dans gel coat sanitaire;
 Antibactéries;
 Finition ardoise;
 Bonde siphonné Ø90 incluse;
 Receveur de douche avec 30mm de hauteur;
 Grill en acier inox 316 avec 145mm;
 Possibilité de le client coupe sur mesure.



PLANSTONE ARDÓSIA

1600x800
info p.84/p.278



CORES DISPONÍVEIS (por encomenda)
 OUTRAS CORES (sob consulta)
 AVAILABLE COLORS (by order)
 OTHER COLORS (under request)
 COULEURS DISPONIBLES (sur demande)
 AUTRES COULEURS (sur demande)

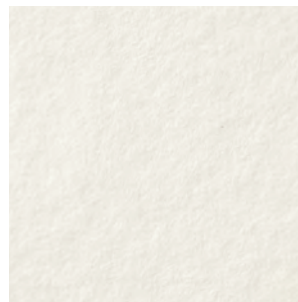

BRANCO
 WHITE | BLANC



BEGE
 BEIGE | BEIGE



CINZA
 GRAY | GRIS

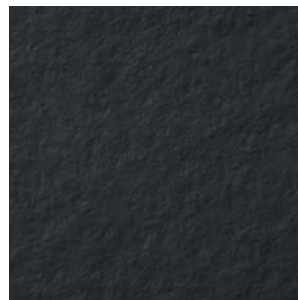

ANTRACITE
 ANTHRACITE | ANTHRACITE



MALVA
 MAUVE | MAUVE



MOKA
 MOKA | MOKA



CHOCOLATE
 CHOCOLATE | CHOCOLATE

Base de duche Planstone antideslizante;
 Material sólido para superfícies, sem poros e homogêneo, composto por resina poliéster, matérias naturais e acabamento em gel coat sanitário;
 Antibactérias;
 Textura de pedra;
 Válvula de descarga sifonada Ø90 incluída;
 Aba 30mm;
 Grelha quadrada de aço inox 316 com 145mm;
 Possibilidade do cliente cortar à medida.

Anti-slip Planstone showertray;
 Solid material to surfaces without pores and homogeneous, composed of polyester resin, natural materials and finished in gel coat sanitary;
 Antibacterial;
 Stone finish;
 Includes siphoned Ø90 wastpipe;
 30mm high shower tray;
 316 stainless steel grill with 145mm;
 Possibility of customer cut to measure.

Receveur de douche Planstone antidérapant;
 Matériau solide pour surfaces sans pores et homogène, composé d'une résine de polyester, des matériaux naturels et fini dans gel coat sanitaire;
 Antibactéries;
 Finition pierre;
 Bonde siphonné Ø90 incluse;
 Receveur de douche avec 30mm de hauteur;
 Grill en acier inox 316 avec 145mm;
 Possibilité de le client coupe sur mesure.





PLANSTONE

PEDRA

1700x750
info p.85-86/p.278



CORES DISPONÍVEIS (por encomenda)
 OUTRAS CORES (sob consulta)
 AVAILABLE COLORS (by order)
 OTHER COLORS (under request)
 COULEURS DISPONIBLES (sur demande)
 AUTRES COULEURS (sur demande)

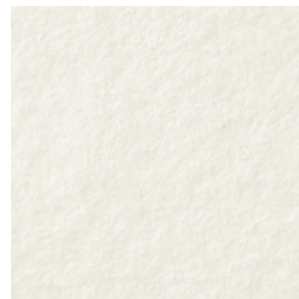

BRANCO
 WHITE | BLANC



BEGE
 BEIGE | BEIGE

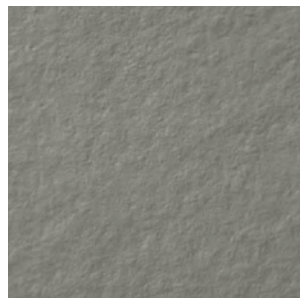

CINZA
 GRAY | GRIS

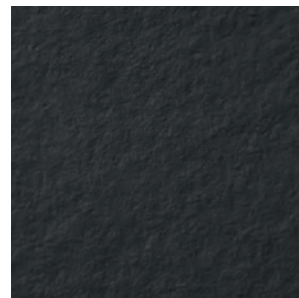

ANTRACITE
 ANTHRACITE | ANTHRACITE



MALVA
 MAUVE | MAUVE



MOKA
 MOKA | MOKA



CHOCOLATE
 CHOCOLATE | CHOCOLATE

Base de duche Planstone antideslizante;
 Material sólido para superfícies, sem poros e homogéneo, composto por resina poliéster, matérias naturais e acabamento em gel coat sanitário;
 Antibactérias;
 Textura de pedra;
 Válvula de descarga sifonada Ø90 incluída;
 Aba 30mm;
 Grelha quadrada de aço inox 316 com 145mm;
 Possibilidade do cliente cortar à medida.

Anti-slip Planstone showertray;
 Solid material to surfaces without pores and homogeneous, composed of polyester resin, natural materials and finished in gel coat sanitary;
 Antibacterial;
 Stone finish;
 Includes siphoned Ø90 wastpipe;
 30mm high shower tray;
 316 stainless steel grill with 145mm;
 Possibility of customer cut to measure.

Receveur de douche Planstone antidérapant;
 Matériau solide pour surfaces sans pores et homogène, composé d'une résine de polyester, des matériaux naturels et fini dans gel coat sanitaire;
 Antibactéries;
 Finition pierre;
 Bonde siphonné Ø90 incluse;
 Receveur de douche avec 30mm de hauteur;
 Grill en acier inox 316 avec 145mm;
 Possibilité de le client coupe sur mesure.



PLANSTONE

PEDRA

900x900
info p.85/p.278

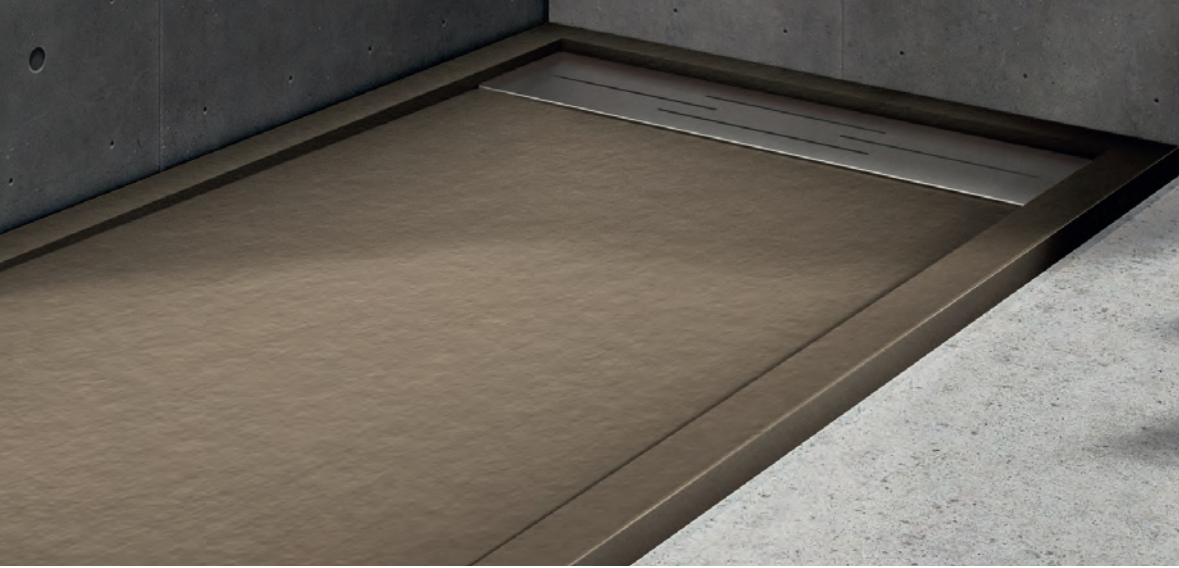

CORES DISPONÍVEIS (por encomenda)
 OUTRAS CORES (sob consulta)
 AVAILABLE COLORS (by order)
 OTHER COLORS (under request)
 COULEURS DISPONIBLES (sur demande)
 AUTRES COULEURS (sur demande)

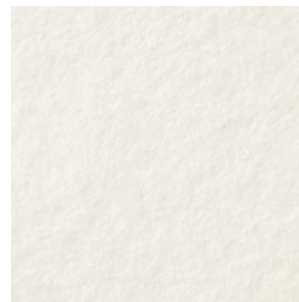

BRANCO
 WHITE | BLANC



BEGE
 BEIGE | BEIGE



CINZA
 GRAY | GRIS

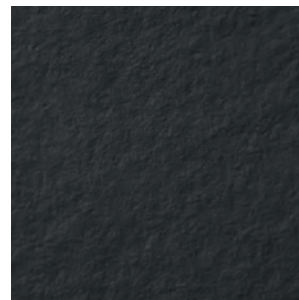

ANTRACITE
 ANTHRACITE | ANTHRACITE



MALVA
 MAUVE | MAUVE



MOKA
 MOKA | MOKA



CHOCOLATE
 CHOCOLATE | CHOCOLATE

Base de duche Planstone Plus antideslizante;
 Material sólido para superfícies, sem poros e homogêneo, composto por resina poliéster, matérias naturais e acabamento em gel coat sanitário;
 Antibactérias;
 Textura de pedra;
 Válvula de descarga sifonada Ø90 incluída;
 Aba 35mm;
 Grelha retangular de aço inox 316;
 Possibilidade do cliente cortar à medida.

Anti-slip Planstone Plus showertray;
 Solid material to surfaces without pores and homogeneous, composed of polyester resin, natural materials and finished in gel coat sanitary;
 Antibacterial;
 Stone finish;
 Includes siphoned Ø90 wastpipe;
 35mm high shower tray;
 316 stainless steel grill;
 Possibility of customer cut to measure.

Receveur de douche Planstone Plus antidérapant;
 Matériau solide pour surfaces sans pores et homogène, composé d'une résine de polyester, des matériaux naturels et fini dans gel coat sanitaire;
 Antibactéries;
 Finition pierre;
 Bonde siphonné Ø90 incluse;
 Receveur de douche avec 35mm de hauteur;
 Grill en acier inox 316;
 Possibilité de le client coupe sur mesure.





PLANSTONE PLUS

PEDRA

1600x800
info p.87/p.280-281



PAINÉIS PLANSTONE PEDRA/ARDÓSIA p.87/p.282

PANELS PLANSTONE STONE/SLATE
PANNEAU PLANSTONE PIERRE/ARDOISE

PAINEL DE ACABAMENTO FINISHING PANEL | PANNEAU DE FINITION



CORES DISPONÍVEIS (por encomenda)
OUTRAS CORES (sob consulta)
AVAILABLE COLORS (by order)
OTHER COLORS (under request)
COULEURS DISPONIBLES (sur demande)
AUTRES COULEURS (sur demande)

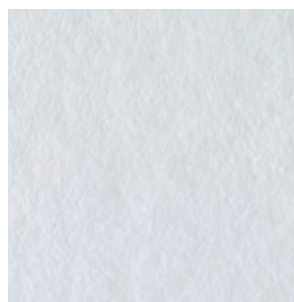

BRANCO
WHITE | BLANC

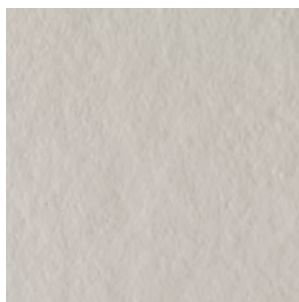

BEGE
BEIGE | BEIGE



CINZA
GRAY | GRIS

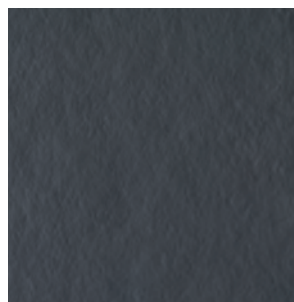

ANTRACITE
ANTHRACITE | ANTHRACITE



MALVA
MAUVE | MAUVE

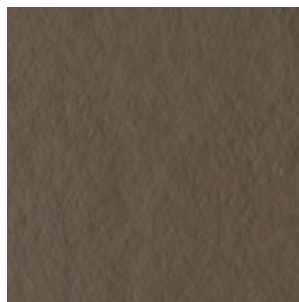

MOKA
MOKA | MOKA

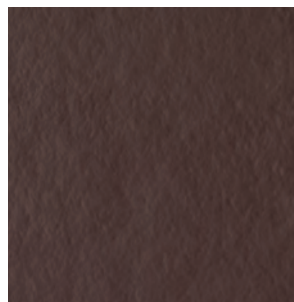

CHOCOLATE
CHOCOLATE | CHOCOLATE

Material sólido para superfícies, sem poros e homogêneo, composto por resina poliéster, matérias naturais e acabamento em gel coat sanitário;
Antibactérias;
Textura de pedra ou ardósia;
Não inclui torneiras;
Painéis fixos com cola poliuretano.

Solid material to surfaces without pores and homogeneous, composed of polyester resin, natural materials and finished in gel coat sanitary;
Antibacterial;
Stone or slate finish;
Taps non included;
Panel fixed with polyurethane glue.

Matériau solide pour surfaces sans pores et homogène, composé d'une résine de polyester, des matériaux naturels et fini dans gel coat sanitaire;
Antibactériés;
Finition pierre ou ardoise;
Robinetterie non incluse;
Panneau coller avec la colle de polyuréthane.





BASE DUCHE EASYHELP 25

EASYHELP 25 SHOWERTRAY
RECEVEUR DE DOUCHE EASYHELP 25

QUADRADA p.50/p.268 SQUARE | CARRÉ



Válvula de descarga sifonada SLIM Ø90 incluida;
Altura interior (cuba) 25mm;
Fundo liso.

Outlet drain slim with waste hole 90mm included;
Interior height 25mm;
Smooth bottom.

Bonde de douche siphonné slim 90mm avec réservoir inclus;
Hauteur intérieure 25mm;
Fond lisse.

A	B	C
800	800	10
900	900	10
1000	1000	10

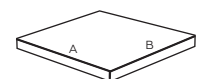

CANTO p.50/p.268 CORNER | D'ANGLE



Válvula de descarga sifonada SLIM Ø90 incluida;
Altura interior (cuba) 25mm;
Fundo liso.

Outlet drain slim with waste hole 90mm included;
Interior height 25mm;
Smooth bottom.

Bonde de douche siphonné slim 90mm avec réservoir inclus;
Hauteur intérieure 25mm;
Fond lisse.

A	B	C
800	800	10
900	900	10
1000	1000	10

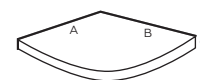



Válvula de descarga sifonada SLIM Ø90 incluída;
 Altura interior (cuba) 25mm;
 Fundo liso.

p.50/p.269 **RETANGULAR**
 RECTANGULAR | RECTANGULAIRE

Outlet drain slim with waste hole 90mm included;
 Interior height 25mm;
 Smooth bottom.

Bonde de douche siphonné slim 90mm avec reservoirie inclus;
 Hauteur intérieure 25mm;
 Fond lisse.

< 74

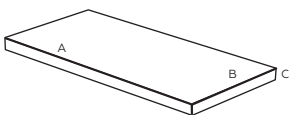

A	B	C	A	B	C	A	B	C	A	B	C
900	700	10	1200	700	10	1500	700	10	1800	700	10
900	750	10	1200	750	10	1500	750	10	1800	750	10
900	800	10	1200	800	10	1500	800	10	1800	800	10
1000	700	10	1200	900	10	1500	900	10	1800	900	10
1000	750	10	1300	700	10	1600	700	10	1900	800	10
1000	800	10	1300	750	10	1600	750	10	1900	900	10
1000	900	10	1300	800	10	1600	800	10	2000	800	10
1100	700	10	1300	900	10	1600	900	10	2000	900	10
1100	750	10	1400	700	10	1700	700	10			
1100	800	10	1400	750	10	1700	750	10			
1100	900	10	1400	800	10	1700	800	10			
			1400	900	10	1700	900	10			



BASE DUCHE EASYHELP 45

EASYHELP 45 SHOWERTRAY
RECEVEUR DE DOUCHE EASYHELP 45

QUADRADA p.52/p.270 SQUARE | CARRÉ



Válvula de descarga sifonada SLIM Ø90 incluida;
Altura interior (cuba) 45mm;
Fundo liso.

Outlet drain slim with waste hole 90mm included;
Interior height 45mm;
Smooth bottom.

Bonde de douche siphonné slim 90mm avec reservoiré inclus;
Hauteur intérieure 45mm;
Fond lisse.

A	B	C
800	800	10
900	900	10
1000	1000	10

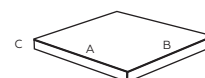

CANTO p.52/p.270 CORNER | D'ANGLE



Válvula de descarga sifonada SLIM Ø90 incluida;
Altura interior (cuba) 45mm;
Fundo liso.

Outlet drain slim with waste hole 90mm included;
Interior height 45mm;
Smooth bottom.

Bonde de douche siphonné slim 90mm avec reservoiré inclus;
Hauteur intérieure 45mm;
Fond lisse.

A	B	C
800	800	10
900	900	10
1000	1000	10

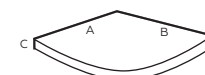

PENTAGONAL p.52/p.270 PENTAGONAL | PENTAGONAL



Válvula de descarga sifonada SLIM Ø90 incluida;
Altura interior (cuba) 45mm;
Fundo liso.

Outlet drain slim with waste hole 90mm included;
Interior height 45mm;
Smooth bottom.

Bonde de douche siphonné slim 90mm avec reservoiré inclus;
Hauteur intérieure 45mm;
Fond lisse.

A	B	C
900	900	10
1000	1000	10

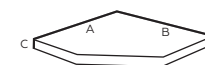



Válvula de descarga sifonada SLIM Ø90 incluida;
 Altura interior (cuba) 45mm;
 Fondo liso.

p.52/p.271 **RETANGULAR**
 RECTANGULAR | RECTANGULAIRE

Outlet drain slim with waste hole 90mm included;
 Interior height 45mm;
 Smooth bottom.

Bonde de douche siphonné slim 90mm avec reservoir inclus;
 Hauteur intérieure 45mm;
 Fond lisse.

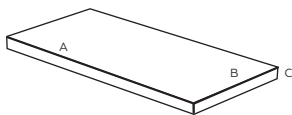

A	B	C	A	B	C	A	B	C	A	B	C
900	700	10	1200	700	10	1500	700	10	1800	700	10
900	750	10	1200	750	10	1500	750	10	1800	750	10
900	800	10	1200	800	10	1500	800	10	1800	800	10
1000	700	10	1200	900	10	1500	900	10	1800	900	10
1000	750	10	1300	700	10	1600	700	10	1900	800	10
1000	800	10	1300	750	10	1600	750	10	1900	900	10
1000	900	10	1300	800	10	1600	800	10	2000	800	10
1100	700	10	1300	900	10	1600	900	10	2000	900	10
1100	750	10	1400	700	10	1700	700	10			
1100	800	10	1400	750	10	1700	750	10			
1100	900	10	1400	800	10	1700	800	10			
			1400	900	10	1700	900	10			



BASE DE DUCHE EXTRAPLANA

EXTRAPLANA SHOWERTRAY
RECEVEUR DE DOUCHE EXTRAPLANA

QUADRADA p.54/p.272 SQUARE | CARRE



Válvula de descarga sifonada SLIM Ø90 incluida;
Altura interior (cuba) 25mm;
Fundo liso.

Outlet drain slim with waste hole 90mm included;
Interior height 25mm;
Smooth bottom.

Bonde de douche siphoné slim 90mm avec reservoirie inclus;
Hauteur intérieure 25mm;
Fond lisse.

A	B	C
800	800	50
900	900	50
1000	1000	50

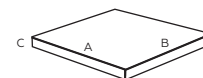

CANTO p.54/p.272 CORNER | D'ANGLE



Válvula de descarga sifonada SLIM Ø90 incluida;
Altura interior (cuba) 25mm;
Fundo liso.

Outlet drain slim with waste hole 90mm included;
Interior height 25mm;
Smooth bottom.

Bonde de douche siphoné slim 90mm avec reservoirie inclus;
Hauteur intérieure 25mm;
Fond lisse.

A	B	C
800	800	50
900	900	50
1000	1000	50

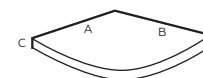

RETANGULAR p.54/p.273 RECTANGULAR | RECTANGULAIRE



Válvula de descarga sifonada SLIM Ø90 incluida;
Altura interior (cuba) 25mm;
Fundo liso.

Outlet drain slim with waste hole 90mm included;
Interior height 25mm;
Smooth bottom.

Bonde de douche siphoné slim 90mm avec reservoirie inclus;
Hauteur intérieure 25mm;
Fond lisse.

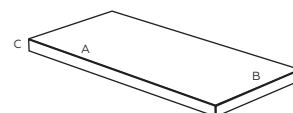

A	B	C	A	B	C	A	B	C	A	B	C
900	700	50	1200	700	50	1500	700	50	1800	700	50
900	750	50	1200	750	50	1500	750	50	1800	750	50
900	800	50	1200	800	50	1500	800	50	1800	800	50
1000	700	50	1200	900	50	1500	900	50	1800	900	50
1000	750	50	1300	700	50	1600	700	50	1900	800	50
1000	800	50	1300	750	50	1600	750	50	1900	900	50
1000	900	50	1300	800	50	1600	800	50	2000	800	50
1100	700	50	1300	900	50	1600	900	50	2000	900	50
1100	750	50	1400	700	50	1700	700	50			
1100	800	50	1400	750	50	1700	750	50			
1100	900	50	1400	800	50	1700	800	50			
			1400	900	50	1700	900	50			

BASE DE DUCHE EXTRAPLANA ESPECIAL*

SPECIAL EXTRAPLANA SHOWERTRAY*
RECEVEUR DE DOUCHE EXTRAPLANA SPÉCIAUX*



*Permite a instalação com válvula sifonada sem partir o piso
*Allows its installation with discharge valve waste without breaking the floor
*Permet d'installation avec valve siphonné sans crasser le sol

Válvula de descarga sifonada SLIM Ø90 incluída;
Altura interior (cuba) 25mm;
Fundo liso.

Outlet drain slim with waste hole 90mm included;
Interior height 25mm;
Smooth bottom.

Bonde de douche siphonné slim 90mm avec reservoirie inclus;
Hauteur intérieure 25mm;
Fond lisse.

p.54/p.272 **QUADRADA**
SQUARE | CARRÉ

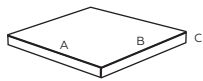

A	B	C
800	800	100
900	900	100
1000	1000	100



Válvula de descarga sifonada SLIM Ø90 incluída;
Altura interior (cuba) 25mm;
Fundo liso.

Outlet drain slim with waste hole 90mm included;
Interior height 25mm;
Smooth bottom.

Bonde de douche siphonné slim 90mm avec reservoirie inclus;
Hauteur intérieure 25mm;
Fond lisse.

p.54/p.272 **CANTO**
CORNER | D'ANGLE

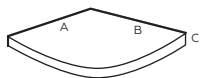

A	B	C
800	800	100
900	900	100
1000	1000	100



Válvula de descarga sifonada SLIM Ø90 incluída;
Altura interior (cuba) 25mm;
Fundo liso.

Outlet drain slim with waste hole 90mm included;
Interior height 25mm;
Smooth bottom.

Bonde de douche siphonné slim 90mm avec reservoirie inclus;
Hauteur intérieure 25mm;
Fond lisse.

p.54/p.273 **RETANGULAR**
RECTANGULAR | RECTANGULAIRE

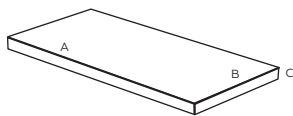

A	B	C	A	B	C	A	B	C	A	B	C
900	700	100	1200	700	100	1500	700	100	1800	700	100
900	750	100	1200	750	100	1500	750	100	1800	750	100
900	800	100	1200	800	100	1500	800	100	1800	800	100
1000	700	100	1200	900	100	1500	900	100	1800	900	100
1000	750	100	1300	700	100	1600	700	100	1900	800	100
1000	800	100	1300	750	100	1600	750	100	1900	900	100
1000	900	100	1300	800	100	1600	800	100	2000	800	100
1100	700	100	1300	900	100	1600	900	100	2000	900	100
1100	750	100	1400	700	100	1700	700	100			
1100	800	100	1400	750	100	1700	750	100			
1100	900	100	1400	800	100	1700	800	100			
			1400	900	100	1700	900	100			



BASE DUCHE PLANÍSSIMA ANTIDERRAPANTE

PLANÍSSIMA SHOWERTRAY NON SLIP
RECEVEUR DE DOUCHE PLANÍSSIMA ANTIGLISSANT

QUADRADA p.56/p.274 SQUARE | CARRÉ



Válvula de descarga sifonada SLIM Ø90 incluída;
Altura interior (cuba) 45mm;
Fundo antiderrapante.

Outlet drain slim with waste hole 90mm included;
Interior height 45mm;
Non slip.

Bonde de douche siphoné slim 90mm avec reservoirie inclus;
Hauteur intérieure 45mm;
Antiglissant.

A	B	C
700	700	75
750	750	75
800	800	75
900	900	75
1000	1000	75

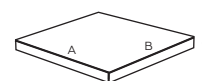

CANTO p.56/p.274 CORNER | D'ANGLE



Válvula de descarga sifonada SLIM Ø90 incluída;
Altura interior (cuba) 45mm;
Fundo antiderrapante.

Outlet drain slim with waste hole 90mm included;
Interior height 45mm;
Non slip.

Bonde de douche siphoné slim 90mm avec reservoirie inclus;
Hauteur intérieure 45mm;
Antiglissant.

A	B	C
750	750	75
800	800	75
900	900	75
1000	1000	75

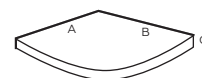

RETANGULAR p.56/p.274 RECTANGULAR | RECTANGULAIRE



Válvula de descarga sifonada SLIM Ø90 incluída;
Altura interior (cuba) 45mm;
Fundo antiderrapante.

Outlet drain slim with waste hole 90mm included;
Interior height 45mm;
Non slip.

Bonde de douche siphoné slim 90mm avec reservoirie inclus;
Hauteur intérieure 45mm;
Antiglissant.

A	B	C
900	700	75
900	750	75
900	800	75
1000	700	75
1000	750	75
1000	800	75
1000	900	75
1100	700	75
1100	750	75
1100	800	75
1100	900	75

A	B	C
1200	700	75
1200	750	75
1200	800	75
1200	900	75
1300	700	75
1300	750	75
1300	800	75
1300	900	75
1400	700	75
1400	750	75
1400	800	75
1400	900	75

A	B	C
1500	700	75
1500	750	75
1500	800	75
1500	900	75
1600	700	75
1600	750	75
1600	800	75
1600	900	75
1700	700	75
1700	750	75
1700	800	75
1700	900	75

A	B	C
1800	700	75
1800	750	75
1800	800	75
1800	900	75
1900	800	75
1900	900	75
2000	800	75
2000	900	75

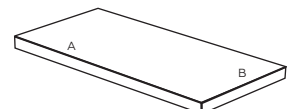

BASE DE DUCHE PLANÍSSIMA

PLANÍSSIMA SHOWERTRAY
RECEVEUR DE DOUCHE PLANÍSSIMA



Válvula de descarga sifonada SLIM Ø90 incluída;
Altura interior (cuba) 45mm;
Fundo liso.

Outlet drain slim with waste hole 90mm included;
Interior height 45mm;
Smooth bottom.

Bonde de douche siphoné slim 90mm avec reservatoire inclus;
Hauteur intérieure 45mm;
Fond lisse.

p.58/p.274 **QUADRADA**
SQUARE | CARRÉ

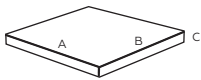

A	B	C
700	700	75
750	750	75
800	800	75
900	900	75
1000	1000	75

Válvula de descarga sifonada SLIM Ø90 incluída;
Altura interior (cuba) 45mm;
Fundo liso.

Outlet drain slim with waste hole 90mm included;
Interior height 45mm;
Smooth bottom.

Bonde de douche siphoné slim 90mm avec reservatoire inclus;
Hauteur intérieure 45mm;
Fond lisse.

p.58/p.274 **CANTO**
CORNER | D'ANGLE

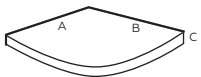

A	B	C
750	750	75
800	800	75
900	900	75
1000	1000	75

Válvula de descarga sifonada SLIM Ø90 incluída;
Altura interior (cuba) 45mm;
Fundo liso.

Outlet drain slim with waste hole 90mm included;
Interior height 45mm;
Smooth bottom.

Bonde de douche siphoné slim 90mm avec reservatoire inclus;
Hauteur intérieure 45mm;
Fond lisse.

p.60/p.274 **PENTAGONAL**
PENTAGONAL | PENTAGONAL

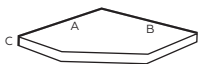

A	B	C
900	900	75
1000	1000	75



BASE DUCHE PLANÍSSIMA

PLANÍSSIMA SHOWERTRAY
RECEVEUR DE DOUCHE PLANÍSSIMA

RETANGULAR p.58/p.275
RECTANGULAR | RECTANGULAIRE

Válvula de descarga sifonada SLIM Ø90 incluida;
Altura interior (cuba) 45mm;
Fundo liso.

Outlet drain slim with waste hole 90mm included;
Interior height 45mm;
Smooth bottom.

Bonde de douche siphonné slim 90mm avec réservoir inclus;
Hauteur intérieure 45mm;
Fond lisse.

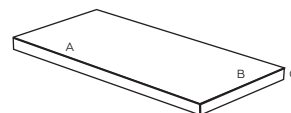

A	B	C	A	B	C	A	B	C	A	B	C
900	700	75	1200	700	75	1500	700	75	1800	700	75
900	750	75	1200	750	75	1500	750	75	1800	750	75
900	800	75	1200	800	75	1500	800	75	1800	800	75
1000	700	75	1200	900	75	1500	900	75	1800	900	75
1000	750	75	1300	700	75	1600	700	75	1900	800	75
1000	800	75	1300	750	75	1600	750	75	1900	900	75
1000	900	75	1300	800	75	1600	800	75	2000	800	75
1100	700	75	1300	900	75	1600	900	75	2000	900	75
1100	750	75	1400	700	75	1700	700	75			
1100	800	75	1400	750	75	1700	750	75			
1100	900	75	1400	800	75	1700	800	75			
			1400	900	75	1700	900	75			



BASE DE DUCHE CLÁSSICA

CLÁSSICA SHOWERTRAY
RECEVEUR DE DOUCHE CLÁSSICA



Válvula de descarga Ø50 não incluída;
Altura interior (cuba) 50mm.
Antiderrapante

Outlet drain 50mm not included;
Interior height 50mm;
Non slip.

Bonde de douche 50mm pas inclus;
Hauteur intérieure 50mm;
Antiglissant.

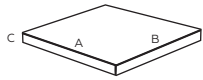

A	B	C
700	700	75
750	750	75
800	800	75
850	850	75
900	900	75

p.62/p.276 **QUADRADA**
SQUARE | CARRÉ



Válvula de descarga Ø50 não incluída;
Altura interior (cuba) 50mm;
Antiderrapante.

Outlet drain 50mm not included;
Interior height 50mm;
Non slip.

Bonde de douche 50mm pas inclus;
Hauteur intérieure 50mm;
Antiglissant.

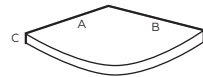

A	B	C
800	800	75
850	850	75
900	900	75

p.62/p.276 **CANTO**
CORNER | D'ANGLE



Válvula de descarga Ø50 não incluída;
Altura interior (cuba) 50mm;
Antiderrapante.

Outlet drain 50mm not included;
Interior height 50mm;
Non slip.

Bonde de douche 50mm pas inclus;
Hauteur intérieure 50mm;
Antiglissant.

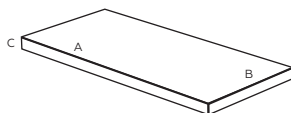

A	B	C
900	750	75
1000	700	75
1000	750	75
1000	800	75
1200	700	75
1200	750	75
1200	800	75
1300	800	75
1400	800	75
1500	800	75

p.62/p.276 **RETANGULAR**
RECTANGULAR | RECTANGULAIRE





BASE DE DUCHE PLANSTONE ARDÓSIA

SLATE PLANSTONE SHOWERTRAY
RECEVEUR DE DOUCHE PLANSTONE ARDOISE

RETANGULAR p.64/p.278
RECTANGULAR | RECTANGULAIRE

Válvula de descarga e grelha de inox 316 quadrada com 145mm incluída.
Outlet drain and stainless 316 square grid with 145mm included.
Bonde de douche et grille en acier inoxydable 316 carré avec 145mm inclus.

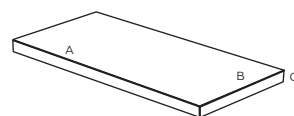

A	B	C	A	B	C
1000	700	30	1600	700	30
1000	800	30	1600	800	30
1000	900	30	1600	900	30
1100	700	30	1600	1000	30
1100	800	30	1700	700	30
1100	900	30	1700	800	30
1100	1000	30	1700	900	30
1200	700	30	1700	1000	30
1200	800	30	1800	700	30
1200	900	30	1800	800	30
1200	1000	30	1800	900	30
1300	700	30	1800	1000	30
1300	800	30	1900	800	30
1300	900	30	1900	900	30
1300	1000	30	1900	1000	30
1400	700	30	2000	800	30
1400	800	30	2000	900	30
1400	900	30	2000	1000	30
1400	1000	30	2100	800	30
1500	700	30	2100	900	30
1500	800	30	2100	1000	30
1500	900	30			
1500	1000	30			

BASE DE DUCHE PLANSTONE PEDRA

STONE PLANSTONE SHOWERTRAY
RECEVEUR DE DOUCHE PLANSTONE PIERRE



Válvula de descarga e grelha de inox 316 quadrada com 145mm incluída.
Outlet drain and stainless 316 square grid with 145mm included.
Bonde de douche et grille en acier inoxydable 316 carré avec 145mm inclus.

p.66/p.277 **QUADRADA**
SQUARE | CARRÉ

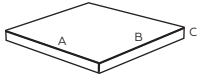

A	B	C
800	800	30
900	900	30
1000	1000	30



Válvula de descarga e grelha de inox 316 quadrada com 145mm incluída.
Outlet drain and stainless 316 square grid with 145mm included.
Bonde de douche et grille en acier inoxydable 316 carré avec 145mm inclus.

p.68/p.277 **CANTO**
CORNER | D'ANGLE



A	B	C
800	800	30
900	900	30
1000	1000	30





BASE DE DUCHE PLANSTONE PEDRA

STONE PLANSTONE SHOWERTRAY
RECEVEUR DE DOUCHE PLANSTONE PIERRE

RETANGULAR p.66/p.278
RECTANGULAR | RECTANGULAIRE

Válvula de descarga e grelha de inox 316 quadrada com 145mm incluída.
Outlet drain and stainless 316 square grid with 145mm included.
Bonde de douche et grille en acier inoxydable 316 carré avec 145mm inclus.

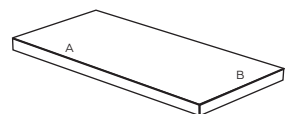

A	B	C	A	B	C
900	700	30	1600	700	30
900	750	30	1600	750	30
900	800	30	1600	800	30
1000	700	30	1600	900	30
1000	750	30	1600	1000	30
1000	800	30	1700	700	30
1000	900	30	1700	750	30
1100	700	30	1700	800	30
1100	750	30	1700	900	30
1100	800	30	1700	1000	30
1100	900	30	1800	700	30
1100	1000	30	1800	750	30
1200	700	30	1800	800	30
1200	750	30	1800	900	30
1200	800	30	1800	1000	30
1200	900	30	1900	700	30
1200	1000	30	1900	750	30
1300	700	30	1900	800	30
1300	750	30	1900	900	30
1300	800	30	1900	1000	30
1300	900	30	2000	800	30
1300	1000	30	2000	900	30
1400	700	30	2000	1000	30
1400	750	30	2100	800	30
1400	800	30	2100	900	30
1400	900	30	2100	1000	30
1400	1000	30	2200	800	30
1500	700	30	2200	900	30
1500	750	30	2200	1000	30
1500	800	30	2300	800	30
1500	900	30	2300	900	30
1500	1000	30	2300	1000	30
			2400	800	30
			2400	900	30
			2400	1000	30
			2500	800	30
			2500	900	30
			2500	1000	30

BASE DE DUCHE PLANSTONE PLUS

PLANSTONE PLUS SHOWERTRAY
RECEVEUR DE DOUCHE PLANSTONE PLUS



Válvula de descarga e grelha de inox 316 retangular incluída.
Outlet drain and stainless 316 rectangular grid included.
Bonde de douche et grille en acier inoxydable 316 rectangulaire inclus.

p.70/p.280-281 **RETANGULAR**
RECTANGULAR | RECTANGULAIRE
PEDRA | STONE | PIERRE

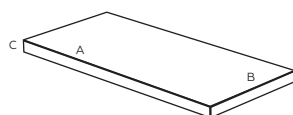

A	B	C	A	B	C
1000	700	35	1600	700	35
1000	750	35	1600	750	35
1000	800	35	1600	800	35
1000	900	35	1600	900	35
1100	700	35	1700	700	35
1100	750	35	1700	750	35
1100	800	35	1700	800	35
1100	900	35	1700	900	35
1200	700	35	1800	700	35
1200	750	35	1800	750	35
1200	800	35	1800	800	35
1200	900	35	1800	900	35
1300	700	35	1900	800	35
1300	750	35	1900	900	35
1300	800	35	2000	800	35
1300	900	35	2000	900	35
1400	700	35			
1400	750	35			
1400	800	35			
1400	900	35			
1500	700	35			
1500	750	35			
1500	800	35			
1500	900	35			



PAINEL DE ACABAMENTO PLANSTONE

p.72/p.282 FINISHING PANEL | PANNEAU DE FINITION

PEDRA/ARDÓSIA | STONE/SLATE | PIERRE/ARDOISE

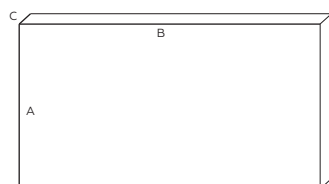

A	B	C
500-1000	700-2100	12





Corpo inox escovado (com opção placa em acrílico branco);
 Misturadora termostática e seletor manual 5 funções com regulador de caudal;
 Controle de temperatura com bloqueio de segurança nos 38°C;
 5 Jatos de hidromassagem orientáveis;
 Braço de inox com cascata incorporada;
 Chuveiro fixo "efeito rain" quadrado 200x200mm com 144 orifícios (20l/3bar);
 Chuveiro de mão retangular com suporte chuveiro e tubo flexível;
 Chuveiro para os pés;
 Possibilidade de instalação em canto a pedido.

Brushed stainless steel structure (with white acrylic sheet option);
 Thermostatic mixer and 5 functions manual selector with flow regulator;
 Temperature control with safety stop at 38°C;
 5 directional whirlpool jets;
 Stainless steel arm with built-in waterfall;
 "Rain-effect" overhead shower square 200x200mm with 144 holes (20l/3bar);
 Rectangular hand shower with showerhead support and flexible hose;
 Foot shower;
 Possibility of installation in corner on request.

Corps en acier inoxydable brossé (en option plaque de acrylique blanc);
 Robinet thermostatique et sélecteur manuel de 5 fonctions avec régulateur de débit;
 Contrôle de température avec butée de sécurité à 38°C;
 5 jets directionnels d'hydro massage;
 Bras en acier inoxydable avec cascade d'eau intégré;
 Pomme de douche "effet de pluie" carré 200x200mm avec 144 trous (20l/3bar);
 Douchette rectangulaire avec support de douchette et flexible de douche;
 Douche pour les pieds;
 Possibilité d'installation dans le coin sur demande.





CASCATA

COLUNA DE HIDROMASSAGEM
HYDROMASSAGE COLUMN COLONNE D'HYDROMASSAGE

1800x220x81 - M

info p.102/p.283

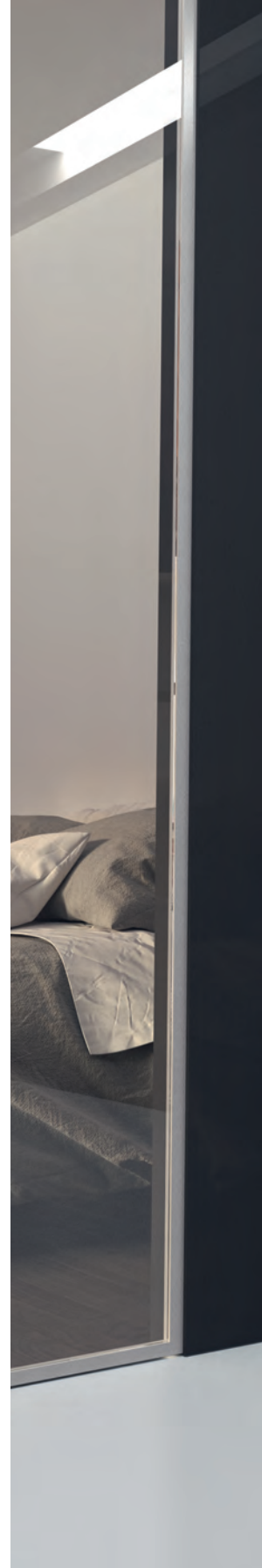

Corpo inox escovado (com opção placa em acrílico branco);

Misturadora termostática e seletor manual 3 funções com regulador de caudal;

Controle de temperatura com bloqueio de segurança nos 38°C;

4 Jatos de hidromassagem orientáveis;

Braço de inox com cascata incorporada;

Chuveiro fixo "efeito rain" quadrado 200x200mm com 144 orifícios (20l/3bar);

Chuveiro de mão retangular com suporte chuveiro e tubo flexível;

Possibilidade de instalação em canto a pedido.

Brushed stainless steel structure (with white acrylic sheet option);

Thermostatic mixer and 3 functions manual selector with flow regulator;

Temperature control with safety stop at 38°C;

4 Directional whirlpool jets;

Stainless steel arm with built-in waterfall;

"Rain-effect" overhead shower square 200x200mm with 144 holes (20l/3bar);

Rectangular hand shower with showerhead support and flexible hose;

Possibility of installation in corner on request.

Corps en acier inoxydable brossé (en option plaque de acrylique blanc);

Robinet thermostatique et sélecteur manuel de 3 fonctions avec régulateur de débit;

Contrôle de température avec butée de sécurité à 38°C;

4 jets directionnels d'hydro massage;

Bras en acier inoxydable avec cascade d'eau intégré;

Pomme de douche "effet de pluie" carré 200x200mm avec 144 trous (20l/3bar);

Douchette rectangulaire avec support de douchette et flexible de douche;

Possibilité d'installation dans le coin sur demande.



CASCATA

COLUNA DE INOX
STAINLESS STEEL COLUMN | COLONNE EN ACIER INOXIDABLE

1500x220x81 - S

info p.103/p.283



Corpo inox escovado (com opção faixa em wengué);

Misturadora termostática e seletor manual 5 funções com regulador de caudal;

Controle de temperatura com bloqueio de segurança nos 38°C;

5 Jatos de hidromassagem orientáveis;

Chuveiro fixo "efeito rain" quadrado 200x200mm com 144 orifícios (20l/3bar);

Chuveiro de mão retangular com suporte de chuveiro e tubo flexível;

Chuveiro para os pés;

Possibilidade de instalação em canto a pedido.

Brushed stainless steel structure (with wengué phenolic strip option);

Thermostatic mixer and 5 functions manual selector with flow regulator;

Temperature control with safety stop at 38°C;

5 Directional whirlpool jets;

"Rain-effect" overhead shower square 200x200mm with 144 holes (20l/3bar);

Rectangular hand shower with showerhead support and flexible hose;

Foot shower;

Possibility of installation in corner on request.

Corps en acier inoxydable brossé (en option phenolique wengué);

Robinet thermostatique et sélecteur manuel de 5 fonctions avec régulateur de débit;

Contrôle de température avec butée de sécurité à 38°C;

5 Jets directionnels d'hydro massage;

Pomme de douche "effet de pluie" carré 200x200mm avec 144 trous (20l/3bar);

Douchette rectangulaire avec support de douchette et flexible de douche;

Douche pour les pieds;

Possibilité d'installation dans le coin sur demande.



COLUNA INOX

COLUMN STAINLESS STEEL | COLONNE ACIER INOXYDABLE

2000x330x81 - L

info p.104/p.284



Corpo em aço inox escovado (com opção placa de acrílico branco);
 Misturadora termostática e seletor manual de 5 funções com regulador de caudal;
 Bloqueio de temperatura aos 38°C;
 5 Jatos de hidromassagem orientáveis;
 Chuveiro fixo "efeito rain" quadrado 200x200mm com 144 orifícios (20l/3bar);
 Chuveiro de mão retangular com suporte de chuveiro e tubo flexível;
 Chuveiro para os pés;
 Possibilidade de instalação em canto a pedido.

Brushed stainless steel structure (with white acrylic sheet optional);
 Thermostatic mixer and 5 functions manual selector with flow regulator;
 Temperature control with safety stop at 38°C;
 5 Directional hydromassage jets;
 "Rain-effect" overhead shower square 200x200mm with 144 holes (20l/3bar);
 Rectangular hand shower with showerhead support and flexible hose;
 Foot shower;
 Possibility of installation in corner on request.

Corps acier inoxydable brossé (en option plaque de acrylique blanc);
 Robinetterie thermostatique et sélecteur manuelle de 5 fonctions avec régulateur de débit;
 Blocage de température à 38°C;
 5 Jets d'hydromassage orientable;
 Douche supérieur "effet de pluie" carré 200x200mm avec 144 trous (20l/3bar);
 Douchette rectangulaire avec porte de douche et flexible;
 Douche pour les pieds;
 Possibilité d'installation dans le coin sur demande.



COLUNA INOX

COLUMN STAINLESS STEEL | COLONNE ACIER INOXYDABLE

1830x250x87 - M

info p.105/p.284



Corpo em aço inox escovado (com opção placa de acrílico branco);
 Misturadora termostática e seletor manual de 3 funções com regulador de caudal;
 Bloqueio de temperatura aos 38°C;
 4 Jatos de hidromassagem orientáveis;
 Chuveiro fixo "efeito rain" quadrado 200x200mm com 144 orifícios (20l/3bar);
 Chuveiro de mão retangular com suporte de chuveiro e tubo flexível;
 Possibilidade de instalação em canto a pedido.

Brushed stainless steel structure (with white acrylic sheet optional);
 Thermostatic mixer and 3 functions manual selector with flow regulator;
 Temperature control with safety stop at 38°C;
 4 Directional hydromassage jets;
 "Rain-effect" overhead shower square 200x200mm with 144 holes (20l/3bar);
 Rectangular hand shower with showerhead support and flexible hose;
 Possibility of installation in corner on request.

Corps acier inoxydable brossé (en option plaque de acrylique blanc);
 Robinetterie thermostatique et sélecteur manuel de 3 fonctions avec régulateur de débit;
 Blocage de température à 38°C;
 4 Jets d'hydromassage orientable;
 Douche supérieur "effet de pluie" carré 200x200mm avec 144 trous (20l/3bar);
 Douchette rectangulaire avec porte de douche et flexible;
 Possibilité d'installation dans le coin sur demande.



COLUNA INOX

COLUMN STAINLESS STEEL | COLONNE ACIER INOXYDABLE

1500x220x81 - S

info p.106/p.285



COLUNA INOX PARA BANHEIRA

Corpo em aço inox escovado (com opção placa em acrílico branco);
 Misturadora termostática e seletor manual de 4 funções com regulador de caudal;
 Bloqueio de temperatura aos 38°C;
 4 jatos de hidromassagem orientáveis;
 Chuveiro fixo quadrado;
 Chuveiro mão retangular com suporte de chuveiro e tubo flexível;
 Bica para banheira com abundante fluxo de água.

STAINLESS STEEL COLUMN FOR BATH TUB

Brushed stainless steel structure (with white acrylic sheet optional);
 Thermostatic mixer and 4 functions manual selector with flow regulator;
 Temperature control with safety stop at 38°C;
 4 directional hydromassage jet;
 Square showerhead;
 Rectangular hand shower with showerhead support, flexible;
 Spout for bath with abundant water flow.

COLONNE EN ACIER INOXYDABLE POUR BAIGNOIRE

Corps acier inoxydable brossé (en option plaque de acrylique blanc);
 Robinetterie thermostatique et sélecteur manuelle de 4 fonctions avec régulateur de débit;
 Blocage de température à 38°;
 4 jets d'hydromassage orientables;
 Douche fixe carré;
 Douchette rectangulaire avec porte de douche et flexible;
 Bec pour baignoire avec flux abondant d'eau.



COLUNA PARA BANHEIRA

BATH TUB COLUMN | COLONNE POUR BAIGNOIRE

1530x250x87

info p.107/p.285

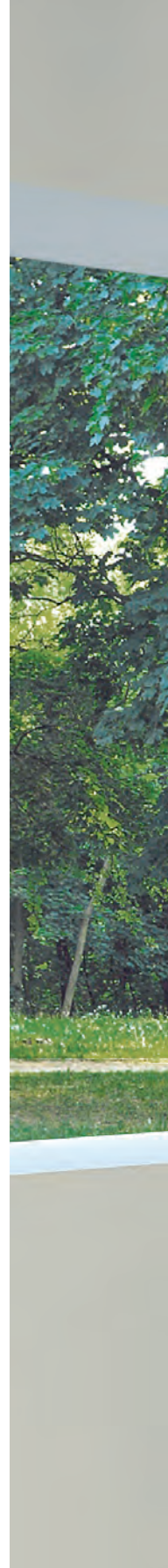

Corpo em aço inox escovado, (com opção placa em acrílico branco);
 Misturadora termostática e seletor manual de 5 funções com regulador de caudal;
 Controle de temperatura com bloqueio de segurança nos 38°C;
 6 Jatos de hidromassagem orientáveis;
 Chuveiro fixo "efeito rain" cilíndrico Ø200mm com 144 orifícios (20l/3bar);
 Chuveiro de mão retangular com suporte de chuveiro e tubo flexível;
 Chuveiro para os pés;
 Possibilidade de instalação em canto a pedido.

Brushed stainless steel structure (with white acrylic sheet optional);
 Thermostatic mixer and 5 functions manual selector with flow regulator;
 Temperature control with safety stop at 38°C;
 6 Directional whirlpool jets;
 "Rain-effect" overhead shower cylindrical Ø200mm with 144 holes (20l/3bar);
 Rectangular hand shower with showerhead support and flexible hose;
 Foot shower;
 Possibility of installation in corner on request.

Corps acier inoxydable brossé (en option plaque de acrylique blanc);
 Robinetterie thermostatique et sélecteur manuel de 5 fonctions avec régulateur de débit;
 Contrôle de température avec butée de sécurité à 38°C;
 6 Jets directionnels d'hydro massage;
 Douche supérieure "effet de pluie" cylindrique Ø200mm avec 144 trous (20l/3bar);
 Douchette rectangulaire avec support de douchette et flexible;
 Douche pour les pieds;
 Possibilité d'installation dans le coin sur demande.



COLUNA ECO

ECO COLUMN | COLONNE ECO

1830x250x87 - M

info p.108/p.286



COLUNA DE HIDROMASSAGEM CASCATA p.88-91/p.283

HYDROMASSAGE CASCATA COLUMN
COLONNE DE HYDROMASSAGE CASCATA



M-ACRÍLICO
M-ACRYLIC
M-ACRYLIQUE

A B C
1830 250 87



M-INOX
M-STAINLESS STEEL
M-ACIER INOXYDABLE

A B C
1800 220 81

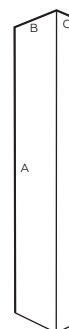

Misturadora termostática;
Seletor manual 5 funções com regulador de caudal;
Controle de temperatura com bloqueio de segurança nos 38°C;
5 Jatos de hidromassagem orientáveis;
Braço de inox com cascata incorporada;
Chuveiro fixo "efeito rain" quadrado 200x200mm com 144 orifícios (20l/3bar);
Chuveiro de mão retangular com suporte chuveiro e tubo flexível;
Chuveiro para os pés;
Possibilidade de instalação em canto a pedido.

Thermostatic mixer;
5 functions manual selector with flow regulator;
Temperature control with safety stop at 38°C;
5 directional whirlpool jets;
Stainless steel arm with built-in waterfall;
"Rain-effect" overhead shower square 200x200mm with 144 holes (20l/3bar);
Rectangular hand shower with showerhead support and flexible hose;
Foot shower;
Possibility of installation in corner on request.

Robinet thermostatique;
Sélecteur manuel de 5 fonctions avec régulateur de débit;
Contrôle de température avec butée de sécurité à 38°C;
5 jets directionnels d'hydro massage;
Bras en acier inoxydable avec cascade d'eau intégré;
Pomme de douche "effet de pluie" carré 200x200mm avec 144 trous (20l/3bar);
Douchette rectangulaire avec support de douchette et flexible de douche;
Douche pour les pieds;
Possibilité d'installation dans le coin sur demande.



S-ACRÍLICO
S-ACRYLIC
S-ACRYLIQUE

A	B	C
1530	250	87



S-INOX
S-STAINLESS STEEL
S-ACIER INOXYDABLE

A	B	C
1500	220	81

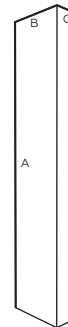

Misturadora termostática;
Seletor manual 3 funções com regulador de caudal;
Controle de temperatura com bloqueio de segurança nos 38°C;
4 Jatos de hidromassagem orientáveis;
Braço de inox com cascata incorporada;
Chuveiro fixo "efeito rain" quadrado 200x200mm com 144 orifícios (20l/3bar);
Chuveiro de mão retangular com suporte chuveiro e tubo flexível;
Possibilidade de instalação em canto a pedido.

Thermostatic mixer;
3 functions manual selector with flow regulator;
Temperature control with safety stop at 38°C;
4 Directional whirlpool jets;
Stainless steel arm with built-in waterfall;
"Rain-effect" overhead shower square 200x200mm with 144 holes (20l/3bar);
Rectangular hand shower with showerhead support and flexible hose;
Possibility of installation in corner on request.

Robinet thermostatique;
Sélecteur manuel de 3 fonctions avec régulateur de débit;
Contrôle de température avec butée de sécurité à 38°C;
4 jets directionnels d'hydro massage;
Bras en acier inoxydable avec cascade d'eau intégré;
Pomme de douche "effet de pluie" carré 200x200mm avec 144 trous (20l/3bar);
Douchette rectangulaire avec support de douchette et flexible de douche;
Possibilité d'installation dans le coin sur demande.



COLUNA DE HIDROMASSAGEM INOX p.92-95/p.284

HYDROMASSAGE STAINLESS STEEL COLUMN
COLONNE DE HYDROMASSAGE EN ACIER INOXYDABLE



L-ACRÍLICO
L-ACRYLIC
L-ACRYLIQUE

A B C
2030 350 87



L-INOX
L-STAINLESS STEEL
L-ACIER INOXYDABLE

A B C
2000 330 81

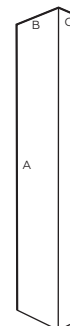

Torneira termostática e seletor manual de 5 funções com regulador de caudal;
Bloqueio de temperatura aos 38°C;
5 Jatos de hidromassagem orientáveis;
Chuveiro fixo "efeito rain" quadrado 200x200mm com 144 orifícios (20l/3bar);
Chuveiro de mão retangular com suporte chuveiro e tubo flexível;
Chuveiro para os pés;
Corpo em aço inox escovado com opção de placa de acrílico branco ou faixa em fenólico;
Possibilidade de instalação em canto a pedido.

Thermostatic mixer and 5 functions manual selector with flow regulator;
Temperature control with safety stop at 38°C;
5 directional hydromassage jet;
"Rain-effect" overhead shower square 200x200mm with 144 holes (20l/3bar);
Rectangular hand shower with showerhead support and flexible hose;
Foot shower;
Brushed stainless steel structure, white acrylic plaque or phenolic strip optional;
Possibility of installation in corner on request.

Robinetterie thermostatique et sélecteur manuel de 5 fonctions avec regulateur de débit;
Blocage de température à 38°C;
5 jets d'hydromassage orientable;
Douche supérieure "effet de pluie" carré 200x200mm avec 144 trous (20l/3bar);
Douchette rectangulaire avec porte de douche et flexible;
Douche pour les pieds;
Corps acier inoxydable brossé en option plaque de acrylique blanc ou latte en phénolique;
Possibilité d'installation dans le coin sur demande.

FAIXA EM FENÓLICO PHENOLIC STRIP | LATTE EN PHÉNOLIQUE

WENGUÉ
WENGUÉ
WENGUÉ

CASTANHO
BROWN
MARRÓN

MEL
HONEY
MIEL

FAIA
BEECH
HÊTRE

ZEBRANO
ZEBRANO
ZEBRANO





M-ACRÍLICO
M-ACRYLIC
M-ACRYLIQUE

A	B	C
1830	250	87



M-INOX
M-STAINLESS STEEL
M-ACIER INOXYDABLE

A	B	C
1800	220	81



Torneira termostática e seletor manual de 5 funções com regulador de caudal;
Bloqueio de temperatura aos 38°C;
5 Jatos de hidromassagem orientáveis;
Chuveiro fixo "efeito rain" quadrado 200x200mm com 144 orifícios (20l/3bar);
Chuveiro de mão retangular com suporte chuveiro e tubo flexível;
Chuveiro para os pés;
Corpo em aço inox escovado com opção placa de acrílico branco;
Possibilidade de instalação em canto a pedido.

Thermostatic mixer and 5 functions manual selector with flow regulator;
Temperature control with safety stop at 38°C;
5 directional hydromassage jet;
"Rain-effect" overhead shower square 200x200mm with 144 holes (20l/3bar);
Rectangular hand shower with showerhead support and flexible hose;
Foot shower;
Brushed stainless steel structure or white acrylic plaque optional;
Possibility of installation in corner on request.

Robinetterie thermostatique et sélecteur manuel de 5 fonctions avec regulateur de débit;
Blocage de température à 38°C;
5 jets d'hydromassage orientable;
Douche supérieure "effet de pluie" carré 200x200mm avec 144 trous (20l/3bar);
Douchette rectangulaire avec porte de douche et flexible;
Douche pour les pieds;
Corps acier inoxydable brossé en option plaque de acrylique blanc;
Possibilité d'installation dans le coin sur demande.



COLUNA DE HIDROMASSAGEM INOX p.96/p.285

HYDROMASSAGE STAINLESS STEEL COLUMN
COLONNE DE HYDROMASSAGE EN ACIER INOXYDABLE



S-ACRÍLICO
S-ACRYLIC
S-ACRYLIQUE

A B C
1530 250 87

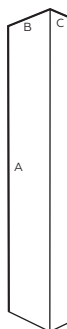

S-INOX
S-STAINLESS STEEL
S-ACIER INOXYDABLE

A B C
1500 220 81

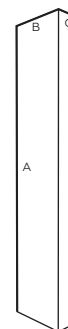

Torneira termostática e seletor manual de 3 funções com regulador de caudal;
Bloqueio de temperatura aos 38°C;
4 Jatos de hidromassagem orientáveis;
Chuveiro fixo "efeito rain" quadrado 200x200mm com 144 orifícios (20l/3bar);
Chuveiro de mão retangular com suporte chuveiro e tubo flexível;
Corpo em aço inox escovado com opção placa de acrílico branco;
Possibilidade de instalação em canto a pedido.

Thermostatic mixer and 3 functions manual selector with flow regulator;
Temperature control with safety stop at 38°C;
4 directional hydromassage jet;
"Rain-effect" overhead shower square 200x200mm with 144 holes (20l/3bar);
Rectangular hand shower with showerhead support and flexible hose;
Brushed stainless steel structure or white acrylic plaque optional;
Possibility of installation in corner on request.

Robinetterie thermostatique et sélecteur manuel de 3 fonctions avec regulateur de débit;
Blocage de température à 38°C;
4 jets d'hydromassage orientable;
Douche supérieure "effet de pluie" carré 200x200mm avec 144 trous (20l/3bar);
Douchette rectangulaire avec porte de douche et flexible;
Corps acier inoxydable brossé en option plaque de acrylique blanc;
Possibilité d'installation dans le coin sur demande.



ACRÍLICO
ACRYLIC
ACRYLIQUE

A	B	C
1530	250	87

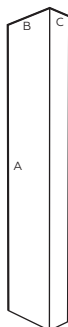

INOX
STAINLESS STEEL
ACIER INOXYDABLE

A	B	C
1500	220	81

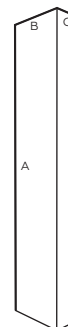

Misturadora termostática;
Seletor manual 3 funções com regulador de caudal;
Controle de temperatura com bloqueio de segurança nos 38°C;
4 Jatos de hidromassagem orientáveis;
Chuveiro fixo quadrado;
Chuveiro de mão retangular com suporte de chuveiro e tubo flexível;
Bica com controlo de caudal e abundante fluxo de água.

Thermostatic mixer;
3 functions manual selector with flow regulator;
Temperature control with safety stop at 38°C;
4 Directional whirlpool jets;
Square showerhead;
Rectangular hand shower with showerhead support and flexible hose;
Spout with flow control and abundant water outlet.

Robinet thermostatique;
Sélecteur manuel de 3 fonctions avec régulateur de débit;
Contrôle de température avec butée de sécurité à 38°C;
4 Jets directionnels d'hydro massage;
Pomme de douche carrée;
Douchette rectangulaire avec support de douchette et flexible;
Bec avec réglage du débit et l'écoulement abondant d'eau.



COLUNA DE HIDROMASSAGEM ECO p.101/p.286

ECO HYDROMASSAGE COLUMN
COLONNE DE HYDROMASSAGE ECO



M-ECO-ACRÍLICO
M-ECO-ACRYLIC
M-ECO-ACRYLIQUE

A B C
1830 250 87

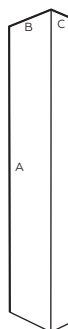

M-ECO-INOX
M-ECO-STAINLESS STEEL
M-ECO-ACIER INOXYDABLE

A B C
1800 220 81

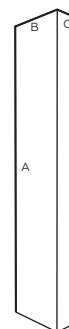

Misturadora termostática;
Seletor manual 5 funções com regulador de caudal;
Controle de temperatura com bloqueio de segurança nos 38°C;
6 Jatos de hidromassagem orientáveis;
Chuveiro fixo "efeito rain" cilíndrico Ø200mm com 144 orifícios (20l/3bar);
Chuveiro de mão retangular com suporte de chuveiro e tubo flexível;
Chuveiro para os pés;
Corpo em aço inox escovado com opção placa de acrílico branco;
Possibilidade de instalação em canto a pedido.

Thermostatic mixer;
5 functions manual selector with flow regulator;
Temperature control with safety stop at 38°C;
6 Directional whirlpool jets;
"Rain-effect" overhead shower cylindrical Ø200mm with 144 holes (20l/3bar);
Rectangular hand shower with showerhead support and flexible hose;
Foot shower;
Brushed stainless steel structure or white acrylic plaque optional;
Possibility of installation in corner on request.

Robinet thermostatique;
Sélecteur manuel de 5 fonctions avec régulateur de débit;
Contrôle de température avec butée de sécurité à 38°C;
6 Jets directionnels d'hydro massage;
Douche supérieure "effet de pluie" cylindrique Ø200mm avec 144 trous (20l/3bar);
Douchette rectangulaire avec support de douchette et flexible;
Douche pour les pieds;
Corps acier inoxydable brossé en option plaque de acrylique blanc;
Possibilité d'installation dans le coin sur demande.



S-ECO-ACRÍLICO
S-ECO-ACRYLIC
S-ECO-ACRYLIQUE

A B C
1530 250 87

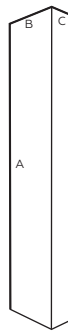

S-ECO-INOX
S-ECO-STAINLESS STEEL
S-ECO-ACIER INOXYDABLE

A B C
1500 220 81

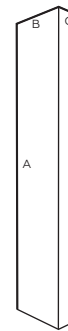

Misturadora termostática;
Seletor manual 3 funções com regulador de caudal;
Controle de temperatura com bloqueio de segurança nos 38°C;
6 Jatos de hidromassagem orientáveis;
Chuveiro fixo "efeito rain" cilíndrico Ø200mm com 144 orifícios (20l/3bar);
Chuveiro de mão retangular com suporte de chuveiro e tubo flexível;
Corpo em aço inox escovado com opção placa de acrílico branco;
Possibilidade de instalação em canto a pedido.

Thermostatic mixer;
3 functions manual selector with flow regulator;
Temperature control with safety stop at 38°C;
6 Directional whirlpool jets;
"Rain-effect" overhead shower cylindrical Ø200mm with 144 holes (20l/3bar);
Rectangular hand shower with showerhead support and flexible hose;
Brushed stainless steel structure or white acrylic plaque optional;
Possibility of installation in corner on request.

Robinet thermostatique;
Sélecteur manuel de 3 fonctions avec régulateur de débit;
Contrôle de température avec butée de sécurité à 38°C;
6 Jets directionnels d'hydro massage;
Douche supérieure "effet de pluie" cylindrique Ø200mm avec 144 trous (20l/3bar);
Douchette rectangulaire avec support de douchette et flexible;
Corps acier inoxydable brossé en option plaque de acrylique blanc;
Possibilité d'installation dans le coin sur demande.



Misturadora termostática e seletor manual de 5 funções com regulador de caudal;
 Controle de temperatura com bloqueio de segurança nos 38°C;
 8 Jatos de hidromassagem orientáveis;
 Chuveiro fixo "efeito rain" redondo Ø200mm com 144 orifícios (20l/3bar);
 Chuveiro de mão retangular com suporte chuveiro e tubo flexível;
 Cascata incorporada no teto da cabine;
 Corpo de cabine em alumínio escovado cinza ou lacado branco;
 Resguardo de duche perfil metalizado / vidro transparente de 6mm;
 Aro em inox para prateleira;
 Opcionalmente: Banco rebatível branco.

Thermostatic mixer and 5 functions manual selector with flow regulator;
 Temperature control with safety stop at 38°C;
 8 Directional whirlpool jets;
 "Rain-effect" overhead shower head round Ø200mm with 144 holes (20l/3bar);
 Rectangular hand shower with showerhead support and flexible hose;
 Waterfall built into the cabin ceiling;
 Cabin body brushed aluminium grey or white lacquered;
 Shower enclosure with profile metallized / transparent glass 6mm;
 Stainless steel hoop for shelf;
 Optionally: White retractile seat.

Robinetterie thermostatique et sélecteur manuelle de 5 fonctions avec régulateur de débit;
 Contrôle de température avec butée de sécurité à 38°C;
 8 Jets directionnels d'hydro massage;
 Pomme de douche "effet de pluie" ronde Ø200mm avec 144 trous (20l/3bar);
 Douchette rectangulaire avec support de douchette et flexible de douche;
 Cascade d'eau intégré dans le plafond de la cabine;
 Corps de cabine brossé gris aluminium ou blanc laqué;
 Parois de douche avec profil métallique / transparent verre 6mm;
 Arceau en acier inoxydable pour étagère;
 En option: siège rétractile blanc.



CABINE INOVA

INOVA CABIN | CABINE INOVA

900x900

info p.116/p.287



Misturadora termostática e seletor manual de 5 funções com regulador de caudal;
 Controle de temperatura com bloqueio de segurança nos 38°C;
 8 Jatos de hidromassagem orientáveis;
 Chuveiro fixo "efeito rain" quadrado 200x200mm com 144 orifícios (20l/3bar);
 Chuveiro de mão retangular com suporte chuveiro e tubo flexível;
 Cascata incorporada no teto da cabine;
 Corpo de cabine em alumínio escovado cinza ou lacado branco;
 Resguardo de duche perfil branco ou metalizado /vidro transparente de 6mm;
 Aro em inox para prateleira;
 Opcionalmente: Banco rebatível branco.

Thermostatic mixer and 5 functions manual selector with flow regulator;
 Temperature control with safety stop at 38°C;
 8 Directional whirlpool jets;
 "Rain-effect" overhead shower square 200x200mm with 144 holes (20l/3bar);
 Rectangular hand shower with showerhead support and flexible hose;
 Waterfall built into the cabin ceiling;
 Cabin body brushed aluminium grey or white lacquered;
 Shower enclosure with profile metallized or white / transparent glass 6mm;
 Stainless steel hoop for shelf;
 Optionally: White retractile seat.

Robinetterie thermostatique et sélecteur manuelle de 5 fonctions avec régulateur de débit;
 Contrôle de température avec butée de sécurité à 38°C;
 8 Jets directionnels d'hydro massage;
 Pomme de douche "effet de pluie" carré 200x200mm avec 144 trous (20l/3bar);
 Douchette rectangulaire avec support de douchette et flexible de douche;
 Cascade d'eau intégré dans le plafond de la cabine;
 Corps de cabine brossé gris aluminium ou blanc laqué;
 Parois de douche avec profil blanc ou métallique / transparent verre 6mm;
 Arceau en acier inoxydable pour étagère;
 En option: siège rétractile blanc.





INOVA

CABINE DE HIDROMASSAGEM | HYDROMASSAGE CABIN | CABINE D'HYDROMASSAGE

900x900

info p.117/p.287



Misturadora termostática e seletor manual de 5 funções com regulador de caudal;
 Controle de temperatura com bloqueio de segurança nos 38°C;
 8 Jatos de hidromassagem orientáveis;
 Chuveiro fixo "efeito rain" quadrado 200x200mm com 144 orifícios (20l/3bar);
 Chuveiro de mão retangular com suporte chuveiro e tubo flexível;
 Cascata incorporada no teto da cabine;
 Corpo de cabine em alumínio escovado cinza ou lacado branco;
 Resguardo de duche perfil branco ou metalizado /vidro transparente de 6mm;
 Aro em inox para prateleira;
 Opcionalmente: Banco rebatível branco.

Thermostatic mixer and 5 functions manual selector with flow regulator;
 Temperature control with safety stop at 38°C;
 8 Directional whirlpool jets;
 "Rain-effect" overhead shower square 200x200mm with 144 holes (20l/3bar);
 Rectangular hand shower with showerhead support and flexible hose;
 Waterfall built into the cabin ceiling;
 Cabin body brushed aluminium grey or white lacquered;
 Shower enclosure with profile metallized or white / transparent glass 6mm;
 Stainless steel hoop for shelf;
 Optionally: White retractile seat.

Robinetterie thermostatique et sélecteur manuelle de 5 fonctions avec régulateur de débit;
 Contrôle de température avec butée de sécurité à 38°C;
 8 Jets directionnels d'hydro massage;
 Pomme de douche "effet de pluie" carré 200x200mm avec 144 trous (20l/3bar);
 Douchette rectangulaire avec support de douchette et flexible de douche;
 Cascade d'eau intégré dans le plafond de la cabine;
 Corps de cabine brossé gris aluminium ou blanc laqué;
 Parois de douche avec profil blanc ou métallique / transparentverre 6mm;
 Arceau en acier inoxydable pour étagère;
 En option: siège rétractile blanc.



INOVA

CABINE DE HIDROMASSAGEM | HYDROMASSAGE CABIN | CABINE D'HYDROMASSAGE

1200x800

info p.118/p.288



CABINE DE HIDROMASSAGEM INOVA p.110-113/p.287

INOVA HYDROMASSAGE CABIN
CABINE D'HYDROMASSAGE INOVA



CANTO
CORNER
D'ANGLE

A	B	C
800	800	2150
900	900	2150

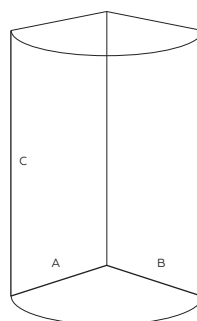

Misturadora termostática e seletor manual de 5 funções com regulador de caudal;
 Controle de temperatura com bloqueio de segurança nos 38°C;
 8 Jatos de hidromassagem orientáveis;
 Chuveiro fixo "efeito rain" redondo Ø200mm com 144 orifícios (20l/3bar);
 Chuveiro de mão retangular com suporte chuveiro e tubo flexível;
 Cascata incorporada no teto da cabine;
 Corpo de cabine em alumínio escovado cinza ou lacado branco;
 Resguardo de duche perfil metalizado / vidro transparente de 6mm;
 Aro em inox para prateleira;
 Opcionalmente: Banco rebatível branco.

Thermostatic mixer and 5 functions manual selector with flow regulator;
 Temperature control with safety stop at 38°C;
 8 Directional whirlpool jets;
 "Rain-effect" overhead shower round Ø200mm with 144 holes (20l/3bar);
 Rectangular hand shower with showerhead support and flexible hose;
 Waterfall built into the cabin ceiling;
 Cabin body brushed aluminium grey or white lacquered;
 Shower enclosure with profile metallized / transparent glass 6mm;
 Stainless steel hoop for shelf;
 Optionally: White retractile seat.

Robinetterie thermostatique et sélecteur manuelle de 5 fonctions avec régulateur de débit;
 Contrôle de température avec butée de sécurité à 38°C;
 8 Jets directionnels d'hydro massage;
 Pomme de douche "effet de pluie" ronde Ø200mm avec 144 trous (20l/3bar);
 Douchette rectangulaire avec support de douchette et flexible de douche;
 Cascade d'eau intégré dans le plafond de la cabine;
 Corps de cabine brossé gris aluminium ou blanc laqué;
 Parois de douche avec profil métallique / transparent verre 6mm;
 Arceau en acier inoxydable pour étagère;
 En option: siège rétractile blanc.



QUADRADA
SQUARE
CARRÉ

A	B	C
800	800	2150
900	900	2150

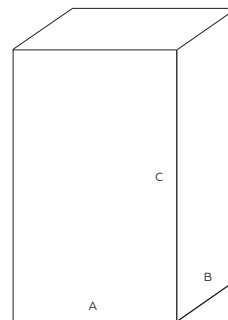

Misturadora termostática e seletor manual de 5 funções com regulador de caudal;
Controle de temperatura com bloqueio de segurança nos 38°C;
8 Jatos de hidromassagem orientáveis;
Chuveiro fixo "efeito rain" quadrado 200x200mm com 144 orifícios (20l/3bar);
Chuveiro de mão retangular com suporte chuveiro e tubo flexível;
Cascata incorporada no teto da cabine;
Corpo de cabine em alumínio escovado cinza ou lacado branco;
Resguardo de duche perfil branco ou metalizado /vidro transparente de 6mm;
Aro em inox para prateleira;
Opcionalmente: Banco rebatível branco.

Thermostatic mixer and 5 functions manual selector with flow regulator;
Temperature control with safety stop at 38°C;
8 Directional whirlpool jets;
"Rain-effect" overhead shower square 200x200mm with 144 holes (20l/3bar);
Rectangular hand shower with showerhead support and flexible hose;
Waterfall built into the cabin ceiling;
Cabin body brushed aluminium grey or white lacquered;
Shower enclosure with profile metallized or white / transparent glass 6mm;
Stainless steel hoop for shelf;
Optionally: White retractile seat.

Robinetterie thermostatique et sélecteur manuelle de 5 fonctions avec régulateur de débit;
Contrôle de température avec butée de sécurité à 38°C;
8 Jets directionnels d'hydro massage;
Pomme de douche "effet de pluie" carré 200x200mm avec 144 trous (20l/3bar);
Douchette rectangulaire avec support de douchette et flexible de douche;
Cascade d'eau intégré dans le plafond de la cabine;
Corps de cabine brossé gris aluminium ou blanc laqué;
Parois de douche avec profil blanc ou métallique / transparent verre 6mm;
Arceau en acier inoxydable pour étagère;
En option: siège rétractile blanc.



CABINE DE HIDROMASSAGEM INOVA p.115/p.288

INOVA HYDROMASSAGE CABIN
CABINE D' HYDROMASSAGE INOVA



RETANGULAR ESQUERDA
RECTANGULAR LEFT
RECTANGULAIRE GAUCHE

A	B	C
1000	800	2150
1000	900	2150
1200	800	2150
1200	900	2150
1400	800	2150
1400	900	2150

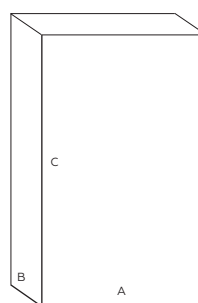

Misturadora termostática e seletor manual de 5 funções com regulador de caudal; Controle de temperatura com bloqueio de segurança nos 38°C;

8 Jatos de hidromassagem orientáveis;
Chuveiro fixo "efeito rain" quadrado 200x200mm com 144 orifícios (20l/3bar);
Chuveiro de mão retangular com suporte chuveiro e tubo flexível;
Cascata incorporada no teto da cabine;
Corpo de cabine esquerdo em alumínio escovado cinza ou lacado branco;
Resguardo de duche perfil branco ou metalizado /vidro transparente de 6mm;
Aro em inox para prateleira;
Opcionalmente: Banco rebatível branco.

Thermostatic mixer and 5 functions manual selector with flow regulator;
Temperature control with safety stop at 38°C;
8 Directional whirlpool jets;
"Rain-effect" overhead shower square 200x200mm with 144 holes (20l/3bar);
Rectangular hand shower with showerhead support and flexible hose;
Waterfall built into the cabin ceiling;
Left cabin body brushed aluminium grey or white lacquered;
Shower enclosure with profile metallized or white / transparent glass 6mm;
Stainless steel hoop for shelf;
Optionally: White retractile seat.

Robinetterie thermostatique et sélecteur manuelle de 5 fonctions avec régulateur de débit;
Contrôle de température avec butée de sécurité à 38°C;
8 Jets directionnels d'hydro massage;
Pomme de douche "effet de pluie" carré 200x200mm avec 144 trous (20l/3bar);
Douchette rectangulaire avec support de douchette et flexible de douche;
Cascade d'eau intégré dans le plafond de la cabine;
Corps de cabine gauche brossé gris aluminium ou blanc laqué;
Parois de douche avec profil blanc ou métallique / transparentverre 6mm;
Arceau en acier inoxydable pour étagère;
En option: siège rétractile blanc.



RETANGULAR DIREITA
RECTANGULAR RIGHT
RECTANGULAIRE DROIT

A	B	C
1000	800	2150
1000	900	2150
1200	800	2150
1200	900	2150
1400	800	2150
1400	900	2150

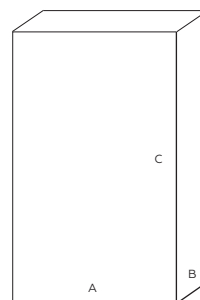

Misturadora termostática e seletor manual de 5 funções com regulador de caudal;
Controle de temperatura com bloqueio de segurança nos 38°C;
8 Jatos de hidromassagem orientáveis;
Chuveiro fixo "efeito rain" quadrado 200x200mm com 144 orifícios (20l/3bar);
Chuveiro de mão retangular com suporte chuveiro e tubo flexível;
Cascata incorporada no teto da cabine;
Corpo de cabine direito em alumínio escovado cinza ou lacado branco;
Resguardo de duche perfil branco ou metalizado /vidro transparente de 6mm;
Aro em inox para prateleira;
Opcionalmente: Banco rebatível branco.

Thermostatic mixer and 5 functions manual selector with flow regulator;
Temperature control with safety stop at 38°C;
8 Directional whirlpool jets;
"Rain-effect" overhead shower square 200x200mm with 144 holes (20l/3bar);
Rectangular hand shower with showerhead support and flexible hose;
Waterfall built into the cabin ceiling;
Right cabin body brushed aluminium grey or white lacquered;
Shower enclosure with profile metallized or white / transparent glass 6mm;
Stainless steel hoop for shelf;
Optionally: White retractile seat.

Robinetterie thermostatique et sélecteur manuelle de 5 fonctions avec régulateur de débit;
Contrôle de température avec butée de sécurité à 38°C;
8 Jets directionnels d'hydro massage;
Pomme de douche "effet de pluie" carré 200x200mm avec 144 trous (20l/3bar);
Douchette rectangulaire avec support de douchette et flexible de douche;
Cascade d'eau intégré dans le plafond de la cabine;
Corps de cabine droite brossé gris aluminium ou blanc laqué;
Parois de douche avec profil blanc ou métallique / transparentverre 6mm;
Arceau en acier inoxydable pour étagère;
En option: siège rétractile blanc.

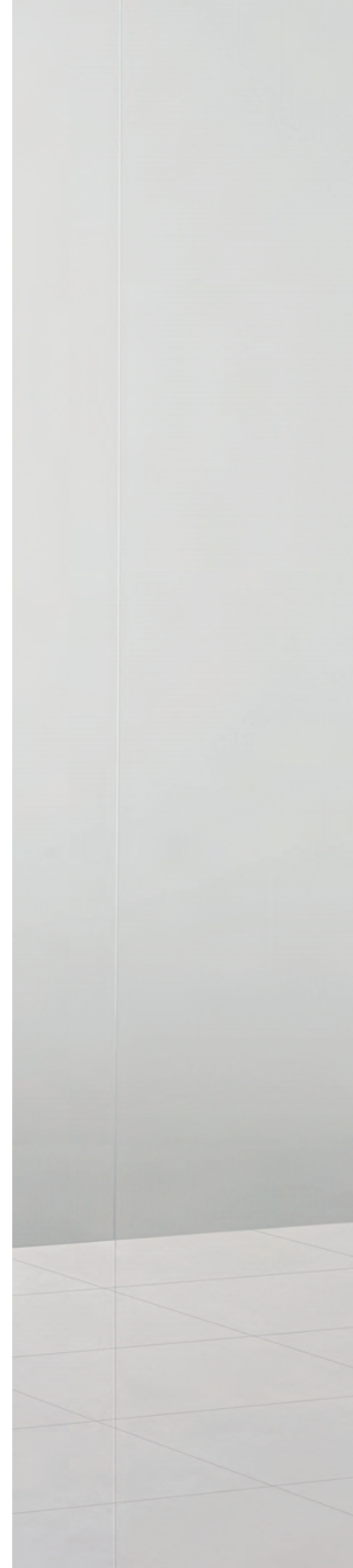

Dois painéis fixos com lateral fixo;
Estrutura de fixação em latão cromado
Ø25mm;
Altura standard 2000mm;
Acessórios em latão cromado;
Perfil em alumínio cromado;
Vidro temperado de 8mm;
Largura do perfil 36mm;
Medidas disponíveis: 1400 a 2200mm;
Estrado não incluído.

Two fixed panels with fixed side;
Clamping arms in chrome-plated brass
Ø25mm;
Standard height 2000mm;
Accessories in chrome-plated brass;
Chrome aluminum profile;
8mm Tempered glass;
Profile width 36mm;
Available measures: 1400 to 2200mm;
Platform not included.

Deux panneaux fixes avec latéral fixe;
Bras de fixation en laiton chromé Ø25mm;
Hauteur standard 2000mm;
Accessoires en laiton chromé;
Profil de l'aluminium chromé;
Verre trempé 8mm;
Profil de largeur 36mm;
Mesures disponibles: 1400 à 2200mm;
Plate-forme non inclus.



PR500

RESGUARDO FRONTAL + LATERAL | FRONTAL + LATERAL SHOWERSCREEN | PARE-DOUCHE FRONTAL + LATÉRAL
info p.289



Um painel fixo esquerdo/direito;
Estrutura de fixação em latão cromado Ø25mm;
Altura standard 2000mm;
Acessórios em latão cromado;
Perfil em alumínio cromado;
Vidro temperado de 8mm;
Largura do perfil 36mm;
Medidas disponíveis: 900 a 1500mm.

Fixed panel left/right;
Clamping arm in chrome-plated brass Ø25mm;
Standard height 2000mm;
Accessories in chrome-plated brass;
Chrome aluminum profile;
8mm Tempered glass;
Profile width 36mm;
Available measures: 900 to 1500mm.



Fixe panneau gauche/droite;
Bras de fixation en laiton chromé Ø25mm;
Hauteur standard 2000mm;
Accessoires en laiton chromé;
Profil de l'aluminium chromé;
Verre trempé 8mm;
Profil de largeur 36mm;
Mesures disponibles: 900 à 1500mm.



PR600

RESGUARDO FRONTAL | FRONTAL SHOWERSCREEN | PARE-DOUCHE FRONTAL
info p.289



Vidro fixo + porta de abrir;
Resguardo especial para banheira Planíssima de canto esquerda/direita;
Estrutura de fixação em latão cromado Ø25mm;
Altura standard 1500mm;
Acessorios em latão cromado;
Perfil em alumínio cromado;
Vidro temperado de 8mm;
Largura do perfil 36mm;
Medidas disponíveis: 650 + 800mm, 700 + 800mm.

Fixed glass + open door;
Special shower-screen for corner Planíssima bathtub left/right;
Clamping arm in chrome-plated brass Ø25mm;
Standard height 1500mm;
Accessories in chrome-plated brass;
Chrome aluminum profile;
8mm Tempered glass;
Profile width 36mm;
Available measures: 650 + 800mm, 700 + 800mm.



Verre fixe + porte d'ouvrir;
Pare-douche spéciale pour baignoire de coin Planíssima gauche/droite;
Bras de fixation en laiton chromé Ø25mm;
Hauteur standard 1500mm;
Accessoires en laiton chromé;
Profil de l'aluminium chromé;
Verre trempé 8mm;
Profil de largeur 36mm;
Mesures disponibles: 650 + 800mm, 700 + 800mm.



PR690

RESGUARDO BANHEIRA PLANÍSSIMA CANTO
PLANÍSSIMA CORNER BATHTUB SHOWERSCREEN | PARE-DOUCHE DE BAIGNOIRE PLANÍSSIMA D'ANGLE
info p.290



Painel de banheira curvo;
Resguardo especial para banheira Charme
de canto;
Altura standard 1500mm;
Comprimento standard 1100mm;
Acessórios em latão cromado;
Vidro temperado de 8mm.

Curved bath panel;
Special shower-screen for corner Charme
bathtub;
Standard height 1500mm;
Standard Length 1100mm;
Accessories in chrome-plated brass;
8mm Tempered glass.

Bain incurvé panneau;
Pare-douche spéciale pour coin baignoire
Charme;
Hauteur standard 1500mm;
Longueur standard 1100mm;
Accessoires en laiton chromé;
Verre trempé 8mm.

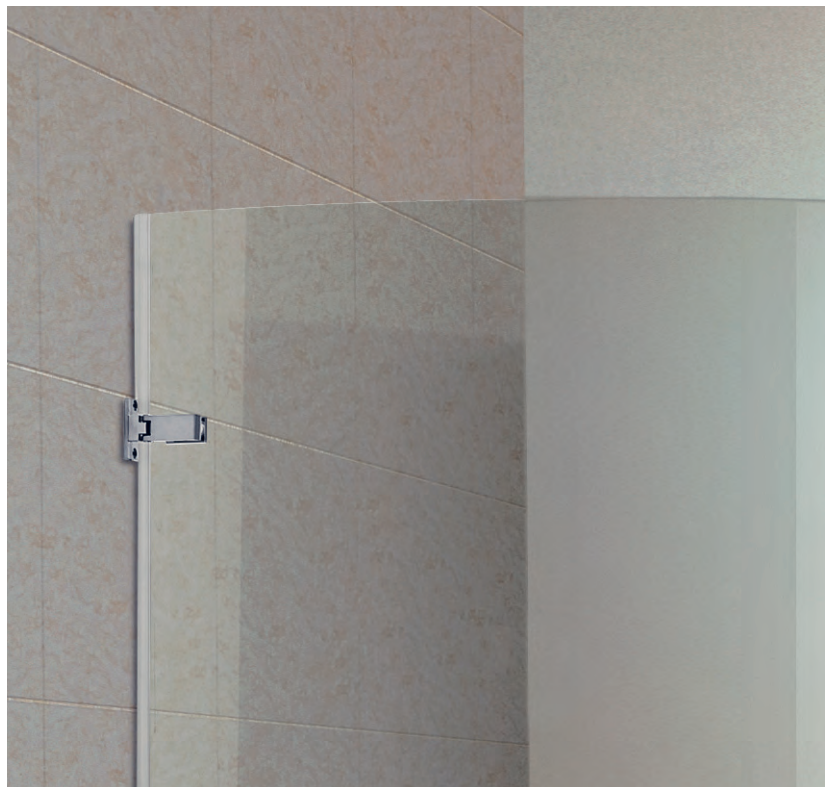

PR691

RESGUARDO BANHEIRA CHARME CANTO
CHARME CORNER BATHTUB SHOWERSCREEN | PARE-DOUCHE DE BAIGNOIRE CHARME D'ANGLE
info p.290



Dois vidros fixos + porta de correr;
Altura standard 2000mm;
Dimensão máxima de P (porta) 900mm;
Acessórios em latão cromado;
Perfil em alumínio cromado;
Vidro temperado de 8mm;
Largura do perfil 36mm;
Medidas disponíveis: 900 a 2000mm;
Estrado não incluído.

Two fixed glass + sliding door;
Standard height 2000mm;
Maximum dimension of P (door) 900mm;
Accessories in chrome-plated brass;
Chrome aluminum profile;
8mm Tempered glass;
Profile width 36mm;
Available measures: 900 to 2000mm;
Platform not included.

Deux verres fixes + porte coulissante;
Hauteur standard 2000mm;
Dimension maximale des P (porte) 900mm;
Accessoires en laiton chromé;
Profil de l'aluminium chromé;
Verre trempé 8mm;
Profil de largeur 36mm;
Mesures disponibles: 900 à 2000mm;
Plate-forme non inclus.



PR710

RESGUARDO FRONTAL | FRONTAL SHOWERSCREEN | PARE-DOUCHE FRONTAL
info p.291



Vidro fixo + porta de correr + vidro lateral;
Altura standard 2000mm;
Dimensao maxima de P (porta) 900mm;
Acessorios em latao cromado;
Vidro temperado de 8mm;
Largura do perfil 36mm;
Medidas disponiveis: 970 a 2400mm;
Estrado não incluido.

Fixed glass + sliding door + lateral glass;
Standard height 2000mm;
Maximum dimension of P (door) 900mm;
Accessories in chrome-plated brass;
8mm tempered glass;
Profile width 36mm;
Available measures: 970 to 2400mm;
Platform not included.

Verre fixe + porte coulissante + verre latéral;
Hauteur standard 2000mm;
Dimension maximale des P (porte) 900mm;
Accessoires en laiton chromé;
Verre trempé 8mm;
Profil de largeur 36mm;
Mesures disponibles: 970 à 2400mm;
Plate-forme non inclus.



PR720

RESGUARDO FRONTAL + LATERAL | FRONTAL + LATERAL SHOWERSCREEN | PARE-DOUCHE FRONTAL + LATÉRAL
info p.291



Dois vidros fixos + porta de abrir;
Estrutura de fixação em latão cromado
Ø25mm;
Altura standard 2000mm;
Acessórios em latão cromado;
Perfil em alumínio cromado;
Vidro temperado de 8mm;
Largura do perfil 36mm;
Medidas disponíveis: 900x900,
1000 x 1000mm.

Two fixed glass + open door;
Clamping arm in chrome-plated brass
Ø25mm;
Standard height 2000mm;
Accessories in chrome-plated brass;
Chrome aluminum profile;
8mm Tempered glass;
Profile width 36mm;
Available measures: 900x900,
1000 x 1000mm.



Deux verres fixes + porte d'ouvrir;
Bras de fixation en laiton chromé Ø25mm;
Hauteur standard 2000mm;
Accessoires en laiton chromé;
Profil de l'aluminium chromé;
Verre trempé 8mm;
Profil de largeur 36mm;
Mesures disponibles: 900x900,
1000 x 1000mm.



PR800

RESGUARDO PENTAGONAL | PENTAGONAL SHOWERSCREEN | PARE-DOUCHE PENTAGONAL
info p.292



Vidro fixo + porta de correr;
Estrutura de fixação em latão cromado
Ø25mm;
Altura standard 2000mm;
Dimensão máxima de P (porta) 900mm;
Acessórios em latão cromado;
Perfil em alumínio cromado;
Vidro temperado de 6mm;
Largura do perfil 33mm;
Medidas disponíveis: 1200 a 2000mm;
Estrado não incluído.

Fixed glass + sliding door;
Clamping arm chrome-plated brass Ø25mm;
Standard height 2000mm;
Maximum dimension of P (door) 900mm;
Accessories in chrome-plated brass;
Chrome aluminum profile;
6mm Tempered glass;
Profile width 33mm;
Available measures: 1200 to 2000mm;
Platform not included.

Verre fixe + porte coulissante;
Bras de fixation en laiton chrome Ø25mm;
Hauteur standard 2000mm;
Dimension maximale de P (porte) 900mm;
Accessoires en laiton chromé;
Profil de l'aluminium chromé;
Verre trempé 6mm;
Profil de largeur 33mm;
Mesures disponibles: 1200 à 2000mm;
Plate-forme non inclus.



IT100

RESGUARDO FRONTAL | FRONTAL SHOWERSCREEN | PARE-DOUCHE FRONTAL
info p.292



Vidro fixo + porta de correr + vidro lateral;
Estrutura de fixação em latão cromado
Ø25mm;
Altura standard 2000mm;
Dimensão máxima de P (porta) 900mm;
Acessórios em latão cromado;
Perfil em alumínio cromado;
Vidro temperado de 6mm;
Largura do perfil 33mm;
Medidas disponíveis: 1600 a 2900mm;
Estrado não incluído.

Fixed glass + sliding door + lateral glass;
Clamping arm chrome-plated brass Ø25mm;
Standard height 2000mm;
Maximum dimension of P (door) 900mm;
Accessories in chrome-plated brass;
Chrome aluminum profile;
6mm Tempered glass;
Profile width 33mm;
Available measures: 1600 to 2900mm;
Platform not included.

Verre fixe + porte coulissante + verre latéral;
Bras de fixation en laiton chrome Ø25mm;
Hauteur standard 2000mm;
Dimension maximale de P (porte) 900mm;
Accessoires en laiton chromé;
Profil de l'aluminium chromé;
Verre trempé 6mm;
Profil de largeur 33mm;
Mesures disponibles: 1600 à 2900mm;
Plate-forme non inclus.



IT150

RESGUARDO FRONTAL + LATERAL | FRONTAL + LATERAL SHOWERSCREEN | PARE-DOUCHE FRONTAL + LATÉRAL
info p.293



Vidro fixo + porta de correr;
Estrutura de fixação em latão cromado
Ø25mm;
Altura standard 1500mm;
Dimensão máxima de P (porta) 900mm;
Acessórios em latão cromado;
Perfil em alumínio cromado;
Vidro temperado de 6mm;
Largura do perfil 33mm;
Medidas disponíveis: 1200 a 2000mm.

Fixed glass + sliding door;
Clamping arm chrome-plated brass Ø25mm;
Standard height 1500mm;
Maximum dimension of P (door) 900mm;
Accessories in chrome-plated brass;
Chrome aluminum profile;
6mm Tempered glass;
Profile width 33mm;
Available measures: 1200 to 2000mm.

Verre fixe + porte coulissante;
Bras de fixation en laiton chrome Ø25mm;
Hauteur standard 1500mm;
Dimension maximale de P (porte) 900mm;
Accessoires en laiton chromé;
Profil de l'aluminium chromé;
Verre trempé 6mm;
Profil de largeur 33mm;
Mesures disponibles: 1200 à 2000mm.



IT200

RESGUARDO FRONTAL DE BANHEIRA | FRONTAL BATHTUB SHOWERSCREEN | PARE-DOUCHE FRONTAL DE BAIGNOIRE
info p.293-294



Vidro fixo + porta de correr;
Estrutura de fixação em latão cromado;
Altura standard 1500mm;
Acessórios em latão cromado;
Perfil em alumínio cromado;
Vidro temperado de 6mm;
Largura do perfil 33mm;
Medidas disponíveis: 900 a 1500mm.

Fixed glass + sliding door;
Clamping arm chrome-plated brass;
Standard height 1500mm;
Accessories in chrome-plated brass;
Chrome aluminum profile;
6mm Tempered glass;
Profile width 33mm;
Available measures: 900 to 1500mm.

Verre fixe + porte coulissante;
Bras de fixation en laiton chrome;
Hauteur standard 1500mm;
Accessoires en laiton chromé;
Profil de l'aluminium chromé;
Verre trempé 6mm;
Profil de largeur 33mm;
Mesures disponibles: 900 à 1500mm.





IT230

RESGUARDO FRONTAL DE BANHEIRA | FRONTAL BATHTUB SHOWERSCREEN | PARE-DOUCHE FRONTAL DE BAIGNOIRE
info p.294



Vidro fixo + porta de abrir;
Estrutura de fixação em latão cromado
Ø25mm;
Altura standard 1500mm;
Acessórios em latão cromado;
Perfil em alumínio cromado;
Vidro temperado de 6mm;
Largura do perfil 33mm;
Medidas disponíveis: 200 + 800mm.

Fixed glass + opening door;
Clamping arm chrome-plated brass Ø25mm;
Standard height 1500mm;
Accessories in chrome-plated brass;
Chrome aluminum profile;
6mm Tempered glass;
Profile width 33mm;
Available measures: 200 + 800mm.

Verre fixe + porte d'ouvrir;
Bras de fixation en laiton chrome Ø25mm;
Hauteur standard 1500mm;
Accessoires en laiton chromé;
Profil de l'aluminium chromé;
Verre trempé 6mm;
Profil de largeur 33mm;
Mesures disponibles: 200 + 800mm.



IT360

RESGUARDO FRONTAL DE BANHEIRA | FRONTAL BATHTUB SHOWERSCREEN | PARE-DOUCHE FRONTAL DE BAIGNOIRE
info p.295



Dois vidros fixos + duas portas de correr;
Altura standard 2000mm;
Rolamentos esferas inox;
Fecho magnético;
Perfil em alumínio lacado branco, metalizado ou cromado;
Vidro temperado de 6mm;
Largura do perfil 52mm;
Medidas disponíveis: 800x800, 850x850, 900x900, 1000x1000mm.

Two fixed glass + two sliding door;
Standard height 2000mm;
Inox ball-bearing rollers;
Magnetic closure;
Lacquered white, methalized or chrome aluminum profile;
6mm tempered glass;
Profile width 52mm;
Available measures: 800x800, 850x850, 900x900, 1000x1000mm.

Deux verre fixes + deux portes coulissantes;
Hauteur standard 2000mm;
Roulements à billes en acier inoxydable;
Fermeture magnétique;
Profil de l'aluminium laqué blanc, métallique ou chromé;
Verre trempé 6mm;
Profil de largeur 52mm;
Mesures disponibles: 800x800, 850x850, 900x900, 1000x1000mm.



TÚNIS

RESGUARDO DE CANTO | CORNER SHOWERSCREEN | PARE-DOUCHE D'ANGLE
info p.295



Dois vidros fixos + duas portas de correr;
 Altura standard 2000mm;
 Rolamentos esferas inox;
 Fecho magnético;
 Perfil em alumínio lacado branco, metalizado ou cromado;
 Vidro temperado de 6mm;
 Largura do perfil 52mm;
 Medidas disponíveis: 700x700, 750x750, 800x800, 850x850, 900x900, 1000x1000mm.

Two fixed glass + two sliding door;
 Standard height 2000mm;
 Inox ball-bearing rollers;
 Magnetic closure;
 Lacquered white, methalized or chrome aluminum profile;
 6mm tempered glass;
 Profile width 52mm;
 Available measures: 700x700, 750x750, 800x800, 850x850, 900x900, 1000x1000mm.

Deux verre fixes + deux portes coulissantes;
 Hauteur standard 2000mm;
 Roulements à billes en acier inoxydable;
 Fermeture magnétique;
 Profil de l'aluminium laqué blanc, métallique ou chromé;
 Verre trempé 6mm;
 Profil de largeur 52mm;
 Mesures disponibles: 700x700, 750x750, 800x800, 850x850, 900x900, 1000x1000mm.



TÚNIS

RESGUARDO CUADRADO | SQUARE SHOWERSCREEN | PARE-DOUCHE CARRÉ
info p.296/297



Dois vidros fixos + duas portas de correr;
Altura standard 2000mm;
Rolamentos esferas inox;
Fecho magnético;
Perfil em alumínio lacado branco, metalizado ou cromado;
Vidro temperado de 6mm;
Largura do perfil 52mm;
Medidas disponíveis: 1200 a 2000mm;
Estrado não incluído.

Two fixed glass + two sliding door;
Standard height 2000mm;
Inox ball-bearing rollers;
Magnetic closure;
Lacquered white, methalized or chrome aluminum profile;
6mm tempered glass;
Profile width 52mm;
Available measures: 1200 to 2000mm;
Platform not included.

Deux verre fixes + deux portes coulissantes;
Hauteur standard 2000mm;
Roulements à billes en acier inoxydable;
Fermeture magnétique;
Profil de l'aluminium laqué blanc, métallique ou chromé;
Verre trempé 6mm;
Profil de largeur 52mm;
Mesures disponibles: 1200 à 2000mm;
Plate-forme non inclus.



TÚNIS

RESGUARDO FRONTAL | FRONTAL SHOWERSCREEN | PARE-DOUCHE FRONTAL
info p.296



Dois Vidros fixos + duas portas de correr + vidro lateral fixo;
 Altura standard 2000mm;
 Rolamentos esferas inox;
 Fecho magnético;
 Perfil em alumínio lacado branco, metalizado ou cromado;
 Vidro temperado de 6mm;
 Largura do perfil 52mm;
 Medidas disponíveis: 1300x700 a 2000x900mm.

Two Fixed glass + two sliding doors + fixed lateral glass;
 Standard height 2000mm;
 Inox ball-bearing rollers;
 Magnetic closure;
 Lacquered white, methalized or chrome aluminum profile;
 6mm Tempered glass;
 Profile width 52mm;
 Available measures: 1300x700 to 2000x900mm.

Deux verre fixes + deux portes coulissantes + verre latéral fixe;
 Hauteur standard 2000mm;
 Roulements à billes en acier inoxydable;
 Fermeture magnétique;
 Profil de l'aluminium laqué blanc, métallique ou chromé;
 Verre trempé 6mm;
 Profil de largeur 52mm;
 Mesures disponibles: 1300x700 à 2000x900mm.



TÚNIS

RESGUARDO FRONTAL + LATERAL | FRONTAL + LATERAL SHOWERSCREEN | PARE-DOUCHE FRONTAL + LATÉRAL
info p.298



Dois Vidros fixos + duas portas de correr + vidro lateral fixo;
 Altura standard 1500mm;
 Rolamentos esferas inox;
 Fecho magnético;
 Perfil em alumínio lacado branco, metalizado ou cromado;
 Vidro temperado de 6mm;
 Largura do perfil 52mm;
 Medidas disponíveis: 1400x700 a 2000x900mm.

Two Fixed glass + two sliding doors + fixed lateral glass;
 Standard height 1500mm;
 Inox ball-bearing rollers;
 Magnetic closure;
 Lacquered white, metalized or chrome aluminum profile;
 6mm Tempered glass;
 Profile width 52mm;
 Available measures: 1400x700 to 2000x900mm.

Deux verre fixes + deux portes coulissantes + verre latéral fixe;
 Hauteur standard 1500mm;
 Roulements à billes en acier inoxydable;
 Fermeture magnétique;
 Profil de l'aluminium laqué blanc, métallique ou chromé;
 Verre trempé 6mm;
 Profil de largeur 52mm;
 Mesures disponibles: 1400x700 à 2000x900mm.



TÚNIS

RESGUARDO DE BANHEIRA | BATHTUB SHOWERSCREEN | PARE-DOUCHE DE BAIGNOIRE
info p.298-299



Dois Vidros fixos + duas portas de correr;
 Altura standard 1850mm;
 Rolamentos esferas inox;
 Fecho magnético;
 Perfil em alumínio lacado branco
 ou metalizado;
 Vidro temperado de 4mm;
 Largura do perfil 38mm;
 Medidas disponíveis: 750x750, 800x800,
 850x850, 900x900, 1000x1000mm.

Two Fixed glass + two sliding doors;
 Standard height 1850 mm;
 Inox ball-bearing rollers; Magnetic closure;
 Lacquered white or methalized aluminum
 profile;
 4mm Tempered glass;
 Profile width 38 mm;
 Available measures: 750x750, 800x800,
 850x850, 900x900, 1000x1000mm.

Deux verre fixes + deux portes coulissantes;
 Hauteur standard 1850 mm;
 Roulements à billes en acier inoxydable;
 Fermeture magnétique;
 Profil de l'aluminium laqué blanc
 ou métallique;
 Verre trempé 4mm;
 Profil de largeur 38mm;
 Mesures disponibles: 750x750, 800x800,
 850x850, 900x900, 1000x1000mm.



CAIRO

RESGUARDO DE CANTO | CORNER SHOWERSCREEN | PARE-DOUCHE D'ANGLE
info p.299



Dois Vidros fixos + duas portas de correr;
 Altura standard 1850mm;
 Rolamentos esferas inox;
 Fecho magnético;
 Perfil em alumínio lacado branco ou metalizado;
 Vidro temperado de 4mm;
 Largura do perfil 38mm;
 Medidas disponíveis: 700x700, 750x750, 800x800, 850x850, 900x900, 1000x1000mm.

Two Fixed glass + two sliding doors;
 Standard height 1850 mm;
 Inox ball-bearing rollers;
 Magnetic closure;
 Lacquered white or methalized aluminum profile;
 4mm Tempered glass;
 Profile width 38 mm;
 Available measures: 700x700, 750x750, 800x800, 850x850, 900x900, 1000x1000mm.

Deux verre fixes + deux portes coulissantes;
 Hauteur standard 1850 mm;
 Roulements à billes en acier inoxydable;
 Fermeture magnétique;
 Profil de l'aluminium laqué blanc ou métallique;
 Verre trempé 4mm;
 Profil de largeur 38mm;
 Mesures disponibles: 700x700, 750x750, 800x800, 850x850, 900x900, 1000x1000mm.



CAIRO

RESGUARDO CUADRADO | SQUARE SHOWERSCREEN | PARE-DOUCHE CARRÉ
info p.300/301



Vidro fixo + porta de correr;
 Altura standard 1850mm;
 Rolamentos esferas inox;
 Fecho magnético;
 Perfil em alumínio lacado branco
 ou metalizado;
 Vidro temperado de 4mm;
 Largura do perfil 38mm;
 Medidas disponíveis: 900 a 2000mm;
 Estrado não incluído.

Fixed glass + sliding door;
 Standard height 1850 mm;
 Inox ball-bearing rollers;
 Magnetic closure;
 Lacquered white or metalized aluminum
 profile;
 4mm Tempered glass;
 Profile width 38 mm;
 Available measures: 900 to 2000mm;
 Platform not included.

Verre fixe + porte coulissante;
 Hauteur standard 1850 mm;
 Roulements à billes en acier inoxydable;
 Fermeture magnétique;
 Profil de l'aluminium laqué blanc
 ou métallique;
 Verre trempé 4mm;
 Profil de largeur 38mm;
 Mesures disponibles: 900 à 2000mm;
 Plate-forme non inclus.



CAIRO

RESGUARDO FRONTAL | FRONTAL SHOWERSCREEN | PARE-DOUCHE FRONTAL
info p.300



Vidro fixo + porta de correr + vidro lateral fixo;
 Altura standard 1850mm;
 Rolamentos esferas inox;
 Fecho magnético;
 Perfil em alumínio lacado branco ou metalizado;
 Vidro temperado de 4mm;
 Largura do perfil 38mm;
 Medidas disponíveis: 1300x700 a 2000x900mm.

Fixed glass + sliding door + fixed lateral glass;
 Standard height 1850 mm;
 Inox ball-bearing rollers;
 Magnetic closure;
 Lacquered white or metalized aluminum profile;
 4mm Tempered glass;
 Profile width 38 mm;
 Available measures: 1300x700 to 2000x900mm.

Verre fixe + porte coulissante + verre latéral fixe;
 Hauteur standard 1850 mm;
 Roulements à billes en acier inoxydable;
 Fermeture magnétique;
 Profil de l'aluminium laqué blanc ou métallique;
 Verre trempé 4mm;
 Profil de largeur 38mm;
 Mesures disponibles: 1300x700 à 2000x900mm.





CAIRO

RESGUARDO FRONTAL + LATERAL | FRONTAL + LATERAL SHOWERSCREEN | PARE-DOUCHE FRONTAL + LATÉRAL
info p.302



Vidro fixo + porta de correr + vidro lateral fixo;
 Altura standard 1400mm;
 Rolamentos esferas inox;
 Fecho magnético;
 Perfil em alumínio lacado branco ou metalizado;
 Vidro temperado de 4mm;
 Largura do perfil 38mm;
 Medidas disponíveis: 1400x700 a 2000x900mm.

Fixed glass + sliding door + fixed lateral glass;
 Standard height 1400 mm;
 Inox ball-bearing rollers;
 Magnetic closure;
 Lacquered white or metalized aluminum profile;
 4mm Tempered glass;
 Profile width 38 mm;
 Available measures: 1400x700 to 2000x900mm.



Verre fixe + porte coulissante + verre latéral fixe;
 Hauteur standard 1400 mm;
 Roulements à billes en acier inoxydable;
 Fermeture magnétique;
 Profil de l'aluminium laqué blanc ou métallique;
 Verre trempé 4mm;
 Profil de largeur 38mm;
 Mesures disponibles: 1400x700 à 2000x900mm.



CAIRO

RESGUARDO DE BANHEIRA | BATHTUB SHOWERSCREEN | PARE-DOUCHE DE BAIGNOIRE
info p.303



Painel duplo de banheira;
 Altura standard 1500mm;
 Comprimento standard 800 + 450mm;
 Perfil em alumínio lacado branco, metalizado
 ou cromado;
 Vidro temperado de 6mm;
 Largura perfil 67mm.

Bathtub double panel;
 Standard height 1500mm;
 Standard length 800 + 450mm;
 Lacquered white, metalized or chrome
 aluminum profile;
 6mm Tempered glass;
 Profile width 67mm.

Panneau de bain double face;
 Hauteur standard 1500mm;
 Longueur standard 800 + 450mm;
 Profil de l'aluminium laqué blanc, métallique
 ou chromé;
 Verre trempé 6mm;
 Profil de largeur 67mm.



TAIPÉ

PAINEL DUPLO | DOUBLE PANEL | PANNEAU DOUBLE
info p.304



TAIPÉ

PAINEL SIMPLES | PANEL SIMPLE | PANNEAU SIMPLE

info p.304

Painel de banheira;
Altura standard 1400mm;
Comprimento standard 850mm;
Perfil em alumínio lacado branco
ou metalizado;
Vidro temperado de 6mm;
Canto curvo;
Largura perfil 67mm.

Bathtub panel;
Standard height 1400mm;
Standard length 850mm;
Lacquered white or metalized aluminum
profile;
6mm Tempered glass;
Curved corner;
Profile width 67mm.

Panneau pour baignoire;
Hauteur standard 1400mm;
Longueur standard 850mm;
Profil de l'aluminium laqué blanc
ou métallique;
Verre trempé 6mm;
Coin incurvé;
Profil de largeur 67mm.



TRANSPARENTE
CLEAR
TRANSPARENT

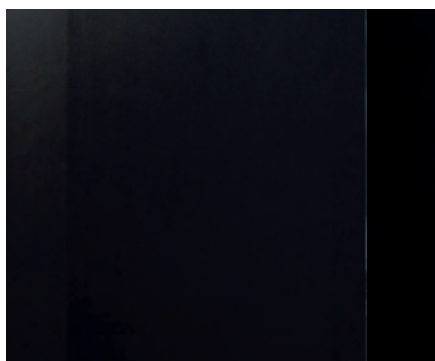

QUADRADOS
SQUARES
CARRÉS

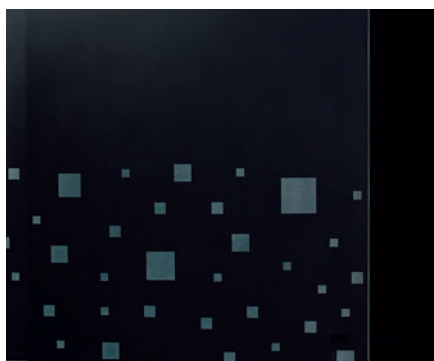

HORIZONTAL
HORIZONTAL
HORIZONTALE



VERTICAL
VERTICAL
VERTICAL

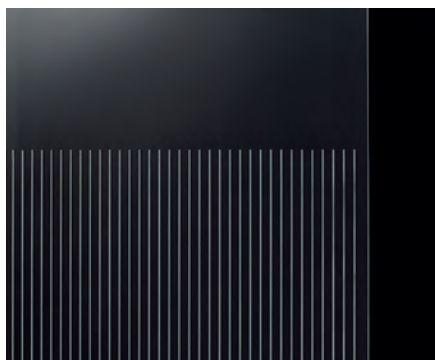

SEMI-OPACO
SEMI-OPAQUE
SEMI-OPAQUE

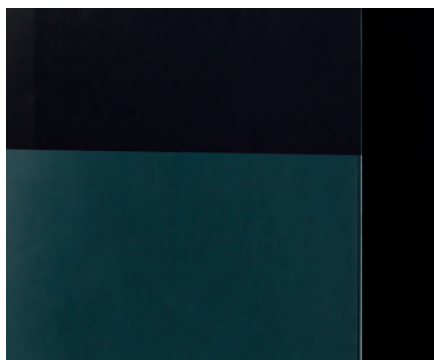

OPACO
OPAQUE
OPAQUE

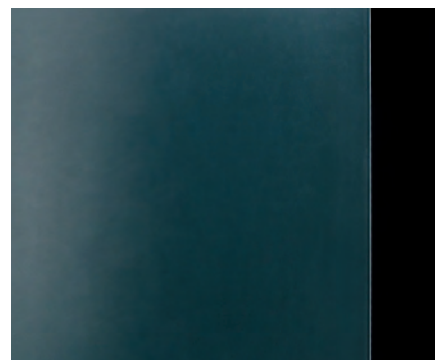

BRANCO
WHITE
BLANC



METALIZADO
METHALIZED
MÉTALLIQUE



CROMADO
CHROMED
CHROME





Conjunto YOLA simples extensível entre 800 a 1500mm;
 Módulo Yola 770mm branco;
 Bancada reversível Yola 800mm wengué aok.
 Conjunto Yola duplo extensível entre 1600 a 2250mm;
 Módulo Yola 770mm branco;
 Duas Bancadas reversíveis Yola 800mm wengué aok.
 Acessórios não incluídos: Espelho, lavatório de posar, sifão e torneira misturadora.

Set simple YOLA extensible 800 to 1500mm;
 Module Yola 770mm white;
 Reversible bench Yola 800mm wengé aok.
 Set double YOLA extensible 1600 to 2250mm;
 Module Yola 770mm white;
 Two reversible benches Yola 800mm wengué aok.
 Accessories not included: Mirror, sink a trend, siphon and single-lever mixer.

Set YOLA simple extensible de 800 à 1500 mm;
 Module Yola 770mm blanc;
 Banc réversible Yola 800mm wengé aok.
 Set Yola double extensible de 1600 à 2250mm;
 Module Yola 770mm blanc;
 Deux bancs réversibles Yola 800mm wengé aok.
 Accessoires non inclus: Miroir, lavabo à poser, siphon et mitigeur.



YOLA

MÓDULO EXTENSÍVEL EXTENSIBLE MODULE MODULE EXTENSIBLE

800-1500 / 1600-2250

info p.305



Móvel Mussulo de 800x540x430mm branco e wengué oak;

Gavetas com soft-close;

Lavatórios disponíveis em cerâmica branca ou vidro temperado branco, laranja, preto, verde pistacho, vermelho e violeta;

Coluna suspensa Mussulo 350x1150x250mm branca e wengué oak com duas prateleiras;

Espelho e acessórios não incluídos.

Cabinet Mussulo 800x540x430mm white and wengé oak;

Drawers with soft-close;

Sinks available in white ceramic or white tempered glass, orange, black, green pistachio, red and violet;

Column suspended Mussulo 350x1150x250mm white and wengue oak with two shelves;

Mirror and accessories not included.

Meuble Mussulo 800x540x430mm blanc et wengé oak;

Tiroirs avec soft-close;

Lavabos disponibles en céramique blanche ou verre trempé blanc, orange, noir, vert pistache, rouge et le violet;

Colonne suspendu Mussulo 350x1150x250mm blanc et wengé oak avec deux étagères;

Miroir et accessoires non inclus.



MUSSULO

800
info p.305



Móvel Sumbe de 900x500x450mm com duas gavetas;
Gavetas com soft-close;
Lavatório Sumbe em cerâmica branco;
Disponível em lacado branco ou preto brilhante;
Espelho e acessórios não incluídos.

Cabinet Sumbe 900x500x450mm with two drawers;
Drawers with soft-close;
Basin Sumbe in white ceramic;
Available in lacquered white or black glossy;
Mirror and accessories not included.

Meuble Sumbe 900x500x450mm avec deux tiroirs;
Tiroirs avec soft-close;
Lavabo Sumbe en céramique blanche;
Disponible en laqué blanc ou noir brillant;
Miroir et accessoires non inclus.



SUMBE

900
info p.305



Conjunto Cuchi 800x450x430mm;
Modulo Cuchi 400mm branco;
Modulo de encastre 370mm branco;
Tampo Cuchi 780mm Branco;
Lavatório Cuchi em cast mineral branco;
Espelho e acessórios não incluídos.

Set Cuchi 800x450x430mm;
Module Cuchi 400mm white;
Built-in module 370mm white;
Top to Cuchi 780mm white;
Sink Cuchi in white mineral cast;
Mirror and accessories not included.

Set Cuchi 800x450x430mm;
Module Cuchi 400mm blanc;
Module intégré 370mm blanc;
Top pour Cuchi 780mm Blanc;
Lavabo Cuchi en blanc cast mineral;
Miroir et accessoires non inclus.



CUCHI

800
info p.305



Móvel Luena 800x810x430mm e 1000x810x430mm;

Móvel 800mm: porta e ½ + gaveta;

Móvel 1000mm: duas portas e ½ + gaveta;

Disponível em lacado branco ou wengué;

Lavatórios disponíveis em cerâmica branca ou vidro temperado branco, laranja, preto, verde pistacho, vermelho e violeta;

Mesita Luena 360x825x325mm;

Porta + gaveta;

Disponível em lacado branco ou wengué;

Espelho e acessórios não incluídos.

Cabinet Luena 800x810x430mm and 1000x810x430mm;

Cabinet 800mm: door and ½ + drawer;

Cabinet 1000mm: two doors and ½ + drawer;

Available in lacquered white or wengé;

Sinks available in white ceramic or white tempered glass, orange, black, green pistachio, red and violet;

Low cabinet Luena 360x825x325mm;

Door + drawer;

Available in lacquered white or wengé;

Mirror and accessories not included.

Meuble Luena 800x810x430mm et 1000x810x430mm;

Meuble 800mm: porte et ½ + tiroir;

Meuble 1000mm: deux ports et ½ + tiroir;

Disponible en laqué blanc ou wenge;

Lavabos disponibles en céramique blanche ou verre trempé blanc, orange, noir, vert pistache, rouge et le violet;

Meuble bas Luena 360x825x325mm;

Porte + tiroir;

Disponible en laqué blanc ou wenge;

Miroir et accessoires non inclus.



LUENA
800/1000
info p.306



Móvel Luena suspenso 800x550x430mm;
 Duas portas e ½ + gaveta;
 Disponível em lacado branco ou wengué;
 Lavatórios disponíveis em cerâmica branca
 ou vidro temperado branco, azul, laranja,
 preto, verde pistacho, vermelho e violeta;
 Espelho e acessórios não incluídos.

Cabinet Luena suspended 800x550x430mm;
 Two doors and ½ + drawer;
 Available in lacquered white or wengé;
 Sinks available in white ceramic or white
 tempered glass, blue, orange, black, green
 pistachio, red and violet;
 Mirror and accessories not included.

Meuble suspendu Luena 800x550x430mm;
 Deux ports et ½ + tiroir;
 Disponible en laqué blanc ou wenge;
 Lavabos disponibles en céramique blanche
 ou verre trempé blanc, bleu, orange, noir, vert
 pistache, rouge et le violet;
 Miroir et accessoires non inclus.



LUENA

MÓVEL SUSPENSO | SUSPENDED CABINET | MEUBLE SUSPENDU

800

info p.306



Coluna Luena 360x1500x325mm;
Duas portas + gaveta;
Disponível em lacado branco ou wengué;
Possível aplicar suspensão;
Espelho e acessórios não incluídos.

Column Luena 360x1500x325mm;
Two doors + drawer;
Available in lacquered white or wengé;
Can apply suspended;
Mirror and accessories not included.



Colonne Luena 360x1500x325mm;
Deux ports + tiroir;
Disponibile en laqué blanc ou wenge;
Pouvez appliquer suspendu;
Miroir et accessoires non inclus.



COLUNA LUENA

LUENA COLUMN | COLONNE LUENA
info p.306



Móvel Viana 600x810x430mm
e 800x810x430mm;

Doas portas;

Disponível em lacado branco ou wengué;

Lavatórios disponíveis em cerâmica branca
ou vidro temperado branco, azul, laranja,
preto, verde pistacho, vermelho e violeta;

Espelho e acessórios não incluídos.

Cabinet Viana 600x810x430mm
and 800x810x430mm;

Two doors;

Available in lacquered white or wengé;

Sinks available in white ceramic or white
tempered glass, blue, orange, black, green
pistachio, red and violet;

Mirror and accessories not included.

Meuble Viana 600x810x430mm
et 800x810x430mm;

Deux ports;

Disponible en laqué blanc ou wenge;

Lavabos disponibles en céramique blanche
ou verre trempé blanc, bleu, orange, noir, vert
pistache, rouge et le violet;

Miroir et accessoires non inclus.



VIANA
600/800
info p.307



Móvel Viana suspenso 600x440x450mm e 800x440x450mm;
 Duas portas;
 Disponível em lacado branco ou wengué;
 Lavatórios disponíveis em cerâmica branca ou vidro temperado branco, azul, laranja, preto, verde pistacho, vermelho e violeta;
 Espelho e acessórios não incluídos.

Cabinet Viana suspended 600x440x450mm and 800x440x450mm;
 Two doors;
 Available in lacquered white or wengé;
 Sinks available in white ceramic or white tempered glass, blue, orange, black, green pistachio, red and violet;
 Mirror and accessories not included.



Meuble suspendu Viana 600x440x450mm et 800x440x450mm;
 Deux ports;
 Disponible en laqué blanc ou wenge;
 Lavabos disponibles en céramique blanche ou verre trempé blanc, bleu, orange, noir, vert pistache, rouge et le violet;
 Miroir et accessoires non inclus.



VIANA

MÓVEL SUSPENSO | SUSPENDED CABINET | MEUBLE SUSPENDU

600/800

info p.307

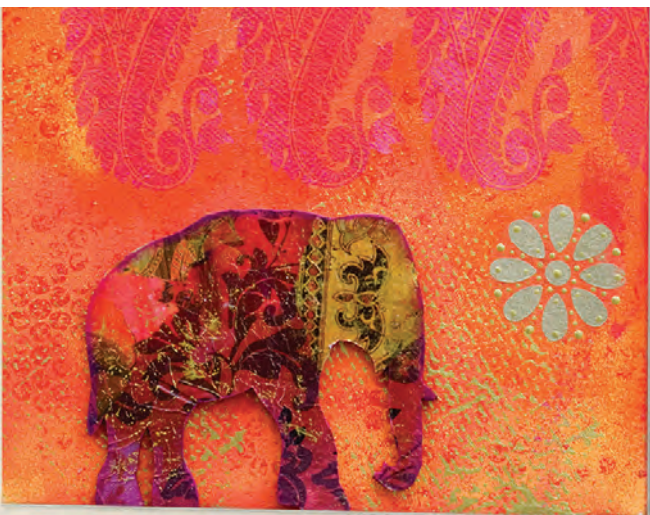

Conjunto móvel Caxito 500x810x310mm
+ lavatório cerâmico branco + espelho;
Duas portas;
Disponível em lacado branco ou wengué;
Acessórios não incluídos.

Cabinet assembly Caxito 500x810x310mm
+ basin white ceramic + mirror;
Two doors;
Available in lacquered white or wengé;
Accessories not included.

Ensemble meuble Caxito 500x810x310mm
+ lavabo en céramique blanche + miroir;
Deux ports;
Disponível en laqué blanc ou wenge;
Accessoires non inclus.



CAXITO

500
info p.307



LAVATÓRIOS DE ENCASTRAR p.308

BASIN TO BUILT-IN
LAVABO À ENCASTRÉE

LAVATÓRIO VIDRO TEMPERADO BRANCO
BASIN IN WHITE TEMPERED GLASS
LAVABO EN VERRE TREMPÉ BLANC



LAVATÓRIO VIDRO TEMPERADO VIOLETA
BASIN IN VIOLET TEMPERED GLASS
LAVABO EN VERRE TREMPÉ VIOLETTE



LAVATÓRIO VIDRO TEMPERADO LARANJA
BASIN IN ORANGE TEMPERED GLASS
LAVABO EN VERRE TREMPÉ ORANGE



LAVATÓRIO VIDRO TEMPERADO VERMELHO
BASIN IN RED TEMPERED GLASS
LAVABO EN VERRE TREMPÉ ROUGE



LAVATÓRIO VIDRO TEMPERADO VERDE PISTACHO
BASIN IN GREEN PISTACHIO TEMPERED GLASS
LAVABO EN VERRE TREMPÉ VERT PISTACHE



LAVATÓRIO VIDRO TEMPERADO PRETO
BASIN IN BLACK TEMPERED GLASS
LAVABO EN VERRE TREMPÉ NOIR



LAVATÓRIO CERÂMICO BRANCO 600/800/1000mm
WHITE CERAMIC BASIN 600/800/1000mm
LAVABO CÉRAMIQUE BLANC 600/800/1000mm



LAVATÓRIO CERÂMICO BRANCO 500mm
WHITE CERAMIC BASIN 500mm
LAVABO CÉRAMIQUE BLANC 500mm





DANDE LAVATÓRIO CERÂMICO BRANCO 400x300mm
DANDE WHITE CERAMIC BASIN 400X300mm
DANDE LAVABO CÉRAMIQUE BLANC 400X300mm



KALANDULA LAVATÓRIO CERÂMICO BRANCO 500x350mm
KALANDULA WHITE CERAMIC BASIN 500x350mm
KALANDULA LAVABO CÉRAMIQUE BLANC 500x350mm



LEBA LAVATÓRIO CERÂMICO BRANCO 400x300mm
LEBA WHITE CERAMIC BASIN 400X300mm
LEBA LAVABO CÉRAMIQUE BLANC 400X300mm



CUITO LAVATÓRIO CERÂMICO BRANCO Ø400mm
CUITO WHITE CERAMIC BASIN Ø400mm
CUITO LAVABO CÉRAMIQUE BLANC Ø400mm



SASSA LAVATÓRIO CERÂMICO BRANCO 520x320mm
SASSA WHITE CERAMIC BASIN 520X320mm
SASSA LAVABO CÉRAMIQUE BLANC 520X320mm



SIFÃO CILINDRICO EM LATÃO CROMADO
SIPHON CYLINDRICAL CHROME PLATED BRASS
SIPHON CYLINDRIQUE EN LAITON CHROMÉ





TORNEIRAS

SINGLE-LEVER MIXERS
MITIGEURS

MONOCOMANDO LAVATÓRIO CROMADO

(Inclui válvula clic clac + 2 torneiras esquadria 1/2"x3/8" com filtro)

SINGLE-LEVER BASIN MIXER (click-clack waste and tap 1/2"x3/8" with filter)

MITIGEUR LAVABO (vidage clic-clac et robinet 1/2"x3/8" avec filtre)



MONOCOMANDO BIDÉ CROMADO

(Inclui válvula clic clac + 2 torneiras esquadria 1/2"x3/8" com filtro)

SINGLE LEVER BIDET MIXER (click-clack waste and tap 1/2"x3/8" with filter)

MITIGEUR BIDET (clic-clac vidage et robinet 1/2"x3/8" avec filtre)



AUMENTO MONOCOMANDO LAVATÓRIO CROMADO 110mmx35mm + KIT BICHAS

EXTENSION FOR SINGLE LEVER BASIN MIXER 110mmx35mm + FLEXIBLE HOSE S

ETEXTENSION POUR MITIGEUR LAVABO 110mmx35mm + FLEXIBLE ENSEMBLE



MONOCOMANDO LAVATÓRIO DE PAREDE CROMADO

SINGLE LEVER BUILT-IN BASIN MIXER WITH WALL FLANGE

MITIGEUR LAVABO À ENCASTRER AVEC BRIDE MURAL

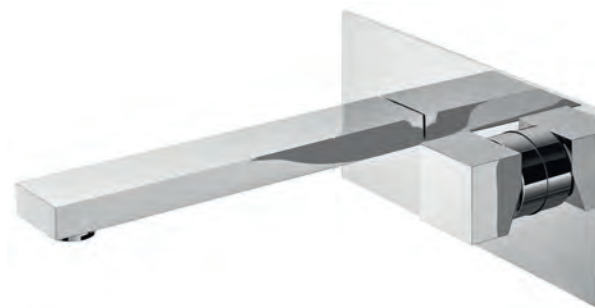

MONOCOMANDO BANHEIRA COM BICA, INVERSOR, CHUVEIRO DE MÃO, SUPORTE E FLEXÍVEL

BATH MIXER WITH SPOUT, DIVERTER, HAND-SHOWER, FLEXIBLE AND SUPPORT

MITIGEUR BAIN MURAL AVEC BEC, INVERSEUR, DOUCHETTE, FLEXIBLE ET SUPPORT



MONOCOMANDO DUCHE CROMADO, CHUVEIRO DE MÃO SUPORTE E FLEXÍVEL

SHOWER MIXER, HAND-SHOWER, FLEXIBLE AND SUPPORT

MITIGEUR DOUCHE MURAL, DOUCHETTE, FLEXIBLE ET SUPPORT





PLAN
info p.309



TORNEIRAS

SINGLE-LEVER MIXERS
MITIGEURS

MONOCOMANDO LAVATÓRIO CROMADO

(Inclui válvula clic clac + 2 torneiras esquadria 1/2x3/8 com filtro)

SINGLE-LEVER BASIN MIXER (click-clack waste and tap 1/2x3/8 with filter)

MITIGEUR LAVABO (vidage clic-clac et robinet 1/2x3/8 avec filtre)



MONOCOMANDO BIDÉ CROMADO

(Inclui válvula clic clac + 2 torneiras esquadria 1/2x3/8 com filtro)

SINGLE LEVER BIDET MIXER (click-clack waste and tap 1/2x3/8 with filter)

MITIGEUR BIDET (clic-clac vidage et robinet 1/2x3/8 avec filtre)



AUMENTO MONOCOMANDO LAVATÓRIO CROMADO 110mmx35mm + KIT BICHAS

EXTENSION FOR SINGLE LEVER BASIN MIXER 110mmx35mm + FLEXIBLE HOSE S

ETEXTENSION POUR MITIGEUR LAVABO 110mmx35mm + FLEXIBLE ENSEMBLE



MONOCOMANDO LAVATÓRIO DE PAREDE CROMADO

SINGLE LEVER BUILT-IN BASIN MIXER WITH WALL FLANGE

MITIGEUR LAVABO À ENCASTRER AVEC BRIDE MURAL



MONOCOMANDO BANHEIRA COM BICA, INVERSOR, CHUVEIRO DE MÃO, SUPORTE E FLEXÍVEL

BATH MIXER WITH SPOUT, DIVERTER, HAND-SHOWER, FLEXIBLE AND SUPPORT

MITIGEUR BAIN MURAL AVEC BEC, INVERSEUR, DOUCHETTE, FLEXIBLE ET SUPPORT



MONOCOMANDO DUCHE, CHUVEIRO DE MÃO SUPORTE E FLEXÍVEL

SHOWER MIXER, HAND-SHOWER, FLEXIBLE AND SUPPORT

MITIGEUR DOUCHE MURAL, DOUCHETTE, FLEXIBLE ET SUPPORT





NASCENTE

info p.310



TORNEIRAS

SINGLE-LEVER MIXERS
MITIGEURS

MONOCOMANDO LAVATÓRIO CROMADO
(Inclui válvula clic clac + 2 torneiras esquadria 1/2"x3/8" com filtro)
SINGLE-LEVER BASIN MIXER (click-clack waste and tap 1/2"x3/8" with filter)
MITIGEUR LAVABO (vidage clic-clac et robinet 1/2"x3/8" avec filtre)



MONOCOMANDO BIDÉ CROMADO
(Inclui válvula clic clac + 2 torneiras esquadria 1/2"x3/8" com filtro)
SINGLE LEVER BIDET MIXER (click-clack waste and tap 1/2"x3/8" with filter)
MITIGEUR BIDET (clic-clac vidage et robinet 1/2"x3/8" avec filtre)



AUMENTO MONOCOMANDO LAVATÓRIO CROMADO
110mmx35mm + KIT BICHAS
EXTENSION FOR SINGLE LEVER BASIN MIXER 110mmx35mm + FLEXIBLE HOSE S
EEXTENSION POUR MITIGEUR LAVABO 110mmx35mm + FLEXIBLE ENSEMBLE



MONOCOMANDO LAVATÓRIO DE PAREDE CROMADO
SINGLE LEVER BUILT-IN BASIN MIXER WITH WALL FLANGE
MITIGEUR LAVABO À ENCASTRER AVEC BRIDE MURAL

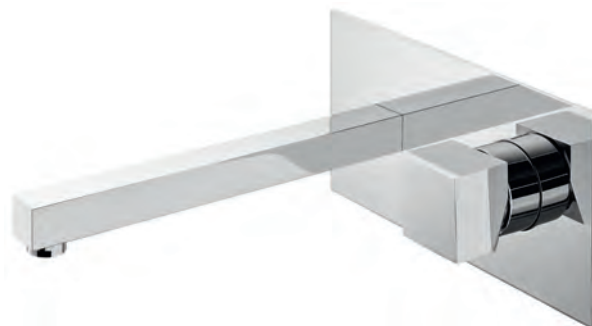

MONOCOMANDO BANHEIRA COM BICA, INVERSOR, CHUVEIRO DE MÃO, SUPORTE E FLEXÍVEL
BATH MIXER WITH SPOUT, DIVERTER, HAND-SHOWER, FLEXIBLE AND SUPPORT
MITIGEUR BAIN MURAL AVEC BEC, INVERSEUR, DOUCHETTE, FLEXIBLE ET SUPPORT



MONOCOMANDO DUCHE, CHUVEIRO DE MÃO SUPORTE E FLEXÍVEL
SHOWER MIXER, HAND-SHOWER, FLEXIBLE AND SUPPORT
MITIGEUR DOUCHE MURAL, DOUCHETTE, FLEXIBLE ET SUPPORT





QUADRA
info p.311



TORNEIRAS

SINGLE-LEVER MIXERS
MITIGEURS

MONOCOMANDO LAVATÓRIO CROMADO

(Inclui válvula clic clac + 2 torneiras esquadria 1/2"x3/8" com filtro)

SINGLE-LEVER BASIN MIXER (click-clack waste and tap 1/2"x3/8" with filter)

MITIGEUR LAVABO (vidage clic-clac et robinet 1/2"x3/8" avec filtre)



MONOCOMANDO BIDÉ CROMADO

(Inclui válvula clic clac + 2 torneiras esquadria 1/2"x3/8" com filtro)

SINGLE LEVER BIDET MIXER (click-clack waste and tap 1/2"x3/8" with filter)

MITIGEUR BIDET (clic-clac vidage et robinet 1/2"x3/8" avec filtre)



AUMENTO MONOCOMANDO LAVATÓRIO CROMADO 110mmx35mm + KIT BICHAS

EXTENSION FOR SINGLE LEVER BASIN MIXER 110mmx35mm + FLEXIBLE HOSE KIT

ETEXTENSION POUR MITIGEUR LAVABO 110mmx35mm + FLEXIBLE ENSEMBLE



MONOCOMANDO LAVATÓRIO DE PAREDE CROMADO

SINGLE LEVER BUILT-IN BASIN MIXER WITH WALL FLANGE

MITIGEUR LAVABO À ENCASTRER AVEC BRIDE MURAL



MONOCOMANDO BANHEIRA COM BICA, INVERSOR, CHUVEIRO DE MÃO, SUPORTE E FLEXÍVEL

BATH MIXER WITH SPOUT, DIVERTER, HAND-SHOWER, FLEXIBLE AND SUPPORT

MITIGEUR BAIN MURAL AVEC BEC, INVERSEUR, DOUCHETTE, FLEXIBLE ET SUPPORT



MONOCOMANDO DUCHE, CHUVEIRO DE MÃO SUPORTE E FLEXÍVEL

SHOWER MIXER, HAND-SHOWER, FLEXIBLE AND SUPPORT

MITIGEUR DOUCHE MURAL, DOUCHETTE, FLEXIBLE ET SUPPORT





CILÍNDRICA

info p.312



ACESSÓRIOS DE DUCHE

SHOWER ACCESSORIES
ACCESSOIRES DE DOUCHE

MONOCOMANDO 2 VIAS CILINDRICO

(liga/desliga água no chuveiro fixo e chuveiro de mão)
CILINDRICO BUILT-IN 2 WAYS OUT SHOWER MIXER
(on/off water in the fixed shower and hand shower)
CILINDRICO MITIGEUR BAIN À ENCASTREUR, 2 SORTIES
(allume et éteint l'eau dans la douche fixée et la douchette)



CHUVEIRO DE TECTO CILINDRICO LATÃO / ABS Ø200,250, 300 E 400mm

CILINDRICO SHOWERTRAY HEAD BRASS/ABS Ø200,250,
300 E 400mm
POMME DE DOUCHE CYLINDRIQUE LAITON/ABS
Ø200,250, 300 E 400mm



BRAÇO CHUVEIRO PAREDE Ø22x400mm CILINDRICO

WALL SHOWER ARM Ø22x400mm
BRAS MURAL DE DOUCHE Ø22x400mm



MONOCOMANDO 1 VIA CILINDRICO

(liga/desliga água no chuveiro fixo)
CILINDRICO BUILT-IN 1 WAY OUT SHOWER MIXER
(on/off water in the fixed shower)
CILINDRICO MITIGEUR BAIN À ENCASTREUR, 1 SORTIE
(allume et éteint l'eau dans la douche fixée)



TOMADA DE ÁGUA COMPLETA + CHUVEIRO DE MÃO CILINDRICO

CILINDRICO COMPLETE SHOWER SET WITH WATER
CONNECTION
ENSEMBLE DE DOUCHE AVEC PRISE D'EAU



BRAÇO CHUVEIRO TETO Ø22x200mm CILINDRICO

CILINDRICO CEILING SHOWER ARM Ø22x200mm
PLAFOND BRAS DE DOUCHE Ø22x200mm CILINDRICO



MONOCOMANDO 2 VIAS QUADRA

(liga/desliga água no chuveiro fixo e chuveiro de mão)
QUADRA BUILT-IN 2 WAYS OUT SHOWER MIXER
(on/off water in the fixed shower and hand shower)
MITIGEUR BAIN À ENCASTREUR, 2 SORTIES QUADRA
(allume et éteint l'eau dans la douche fixée et la douchette)



CHUVEIRO DE TECTO QUADRA LATÃO / ABS 200x200, 250x250, 300x300 E 400x400mm

QUADRA SHOWERTRAY HEAD BRASS/ABS 200x200,
250x250, 300x300 E 400x400mm
POMME DE DOUCHE QUADRA LAITON/ABS 200x200,
250x250, 300x300 E 400x400mm



BRAÇO CHUVEIRO PAREDE 22x22x400mm QUADRA

QUADRA WALL SHOWER ARM 22x22x400mm
BRAS MURAL DE DOUCHE 22x22x400mm QUADRA



MONOCOMANDO 1 VIA QUADRA

(liga/desliga água no chuveiro fixo)
QUADRA BUILT-IN 1 WAY OUT SHOWER MIXER
(on/off water in the fixed shower)
MITIGEUR BAIN À ENCASTREUR, 1 SORTIE QUADRA
(allume et éteint l'eau dans la douche fixée)



TOMADA DE ÁGUA COMPLETA + CHUVEIRO DE MÃO QUADRA

QUADRA COMPLETE SHOWER SET WITH WATER
CONNECTION
ENSEMBLE DE DOUCHE AVEC PRISE D'EAU QUADRA



BRAÇO CHUVEIRO TETO 22x22x200mm QUADRA

QUADRA CEILING SHOWER ARM 22x22x200mm
PLAFOND BRAS DE DOUCHE 22x22x200mm QUADRA





CILÍNDRICA / QUADRA

ACESSÓRIOS DE DUCHE | SHOWER ACCESSORIES | ACCESSOIRES DE DOUCHE
info p.313-314



COLUNAS DE DUCHE

SHOWER COLUMN
COLONNE DE DOUCHE

**CILINDRICA COLUNA DUCHE TERMOSTÁTICA
TELESCÓPICA COM INVERSOR INTEGRADO**
CILINDRICA THERMOSTATIC SHOWER COLUMN TELESCOPIC WITH INTEGRATED
DIVERTER
CILINDRICA COLONNE DE DOUCHE THERMOSTATIQUE TELESCOPIQUE AVEC
CONVERTISSEUR INTÉGRÉ



**QUADRA COLUNA DUCHE TERMOSTÁTICA
TELESCÓPICA COM INVERSOR INTEGRADO**
QUADRA THERMOSTATIC SHOWER COLUMN TELESCOPIC WITH INTEGRATED
DIVERTER
QUADRA COLONNE DE DOUCHE THERMOSTATIQUE TELESCOPIQUE AVEC
CONVERTISSEUR INTÉGRÉ



**CILINDRICA COLUNA DUCHE MONOCOMANDO
TELESCÓPICA COM INVERSOR INTEGRADO**
CILINDRICA TELESCOPIC SHOWER COLUMN WITH MANUAL MIXER
AND INTEGRATED DIVERTER
CILINDRICA COLONNE DE DOUCHE TELESCOPIQUE AVEC MITIGEUR MANUEL
ET CONVERTISSEUR INTÉGRÉ



**QUADRA COLUNA DUCHE MONOCOMANDO
TELESCÓPICA COM INVERSOR INTEGRADO**
QUADRA TELESCOPIC SHOWER COLUMN WITH MANUAL MIXER
AND INTEGRATED DIVERTER
QUADRA COLONNE DE DOUCHE TELESCOPIQUE AVEC MITIGEUR MANUEL
ET CONVERTISSEUR INTÉGRÉ





COLUNAS TELESCÓPICAS

TELESCOPIC SHOWER COLUMN | COLONNE DOUCHE TELESCOPIQUE
info p.315



TOALHEIROS

TOWEL RAILS
PORTE-SERVIETTES

TOALHEIRO BANHEIRA LATÃO 565mm

TOWEL RAIL 565mm
PORTE-SERVIETTE 565mm



TOALHEIRO LAVATÓRIO LATÃO 415mm

TOWEL RAIL 415mm
PORTE-SERVIETTE 415mm



TOALHEIRO BIDÉ LATÃO 265mm

TOWEL RAIL 265mm
PORTE-SERVIETTE 265mm



TOALHEIRO BIDÉ ARGOLA LATÃO 250mm

TOWEL RING 250mm
PORTE-SERVIETTES ANNEAU 250mm



PORTA ROLOS SIMPLS LATÃO

TOILET ROLL HOLDER
RANGE-ROULEAUX WC



SABONETEIRA BANHEIRA/DUCHE LATÃO 250mm

SOAP DISH 250mm
PORTE-SAVON 250mm



ESTANTE LATÃO 500mm

SHELF 500mm
TABLETTE 500mm



CABIDE LATÃO

ROBE HOOK
CROCHET MURALE



SABONETEIRA LAVATÓRIO 120mm

BASIN SOAP DISH 120mm
BASSIN DE SAVON 120mm



TOALHEIRO DE PÉ COM 2 TOALHEIROS LATÃO

STANDING TOWEL HOLDER WITH 2 TOWEL HOLDERS
ACCESSOIRES SUR PIED AVEC 2 PORTE-SERVIETTE



PORTA PIAÇABA CHÃO LATÃO

TOILET BRUSH SET
PORTE-BROSSE WC

PORTA PIAÇABA PAREDE LATÃO

WALL TOILET BRUSH SET
PORTE-BROSSE MURAL DE WC



PRATELEIRA LATÃO/VIDRO

SHELF
TABLETTE





PLANUS
info p.316



TOALHEIROS

TOWEL RAILS
PORTE-SERVIETTES

TOALHEIRO BANHEIRA LATÃO 500mm

TOWEL RAIL 500mm
PORTE-SERVIETTE 500mm



TOALHEIRO LAVATÓRIO LATÃO 400mm

TOWEL RAIL 400mm
PORTE-SERVIETTE 400mm



TOALHEIRO BIDÉ LATÃO 250mm

TOWEL RAIL 250mm
PORTE-SERVIETTE 250mm



PORTA ROLOS SIMPLS LATÃO

TOILET ROLL HOLDER
RANGE-ROULEAUX WC



CABIDE LATÃO

ROBE HOOK
CROCHET MURALE



SABONETEIRA BANHEIRA / DUCHE LATÃO 250mm

SOAP DISH 250mm
PORTE-SAVON 250mm



DOSEADOR DE SABONETE

SOAP DISPENSER
DISTRIBUTEUR SAVON



PORTA PIAÇABA CHÃO LATÃO

TOILET BRUSH SET
PORTE-BROSSE WC

PORTA PIAÇABA PAREDE LATÃO

WALL TOILET BRUSH SET
PORTE-BROSSE MURAL DE WC





MINIMAL
info p.317



A hidromassagem é uma forma terapêutica milenar de utilização da água, que baseia os seus benefícios na ação dinâmica e térmica que a água, sob pressão ou em movimento, exerce sobre a pele e os tecidos provocando o relaxamento físico e sensação de bem-estar. Tem sido igualmente utilizada com êxito pela fisioterapia como efeito terapêutico de reabilitação de lesões musculares ou ainda como auxílio na recuperação de traumas ósseos e na reabilitação ortopédica.

Consciente dos efeitos terapêuticos que a hidromassagem proporciona, a ASD instala nas suas banheiras diferentes tipos de sistemas, utilizando acessórios e componentes fabricados com os mais altos padrões de qualidade.

Os sistemas de hidromassagem ASD encontram-se homologados em conformidade com as normas internacionais harmonizadas, possuindo marcação CE.

The spa is an ancient form of therapeutic use of water, which bases its benefits on dynamic action and thermal water under pressure or in motion, has on the skin and tissues causing physical relaxation and sense of well-being. It has also been used successfully for the therapeutic effect of physiotherapy as rehabilitation of muscle injuries or as an aid in trauma recovery and bone in orthopedic rehabilitation. Aware of the therapeutic effect that the hydro massage provides, ASD in their bathtubs install different types of systems, using components and accessories manufactured with the highest quality.

ASD whirlpool systems are certified in accordance with the harmonized international standards, having CE marking.

Le spa est une forme ancienne de l'utilisation thérapeutique de l'eau, qui fonde ses avantages sur l'action dynamique et l'eau thermique sous pression ou en mouvement, a sur la peau et les tissus, entraînant une détente physique et sentiment de bien-être. Il a également été utilisé avec succès pour l'effet thérapeutique de kinésithérapie que la réhabilitation des blessures musculaires ou comme aide au rétablissement après un traumatisme et d'os dans la réadaptation orthopédique.

Conscient que les effets thérapeutiques du spa offre, l'ASD dans leurs baignoires installe différents types de systèmes, en utilisant des composants et accessoires fabriqués les plus hauts standards de qualité.

L'ASD systèmes hydro massage sont approuvés en conformité avec les normes internationales harmonisées, ayant le marquage CE.



206
207

HIDROMASSAGEM

WHIRLPOOL HYDROMASSAGE



SISTEMAS DE HIDROMASSAGEM p.219/p.263

WHIRLPOOL SYSTEMS
SYSTÈMES DE HYDROMASSAGE



ECOLINE
ECOLINE
ECOLINE



6 injetores de água laterais orientáveis em ABS; Comando pneumático de 2 funções: on/off, massagem de água e regulação manual de caudal (mistura de ar); Crivo de sucção ABS; Motor 650w IP54 230-240-V 3A; Válvula de descarga automática; Ligação equipotencial; 2 anos de garantia contra defeitos de fabrico.

Disponível em cromado.

6 lateral swivelling water jets in ABS; Pneumatic press button control 2 functions: on/off water massage and manual air control; Suction strainer in ABS; 650w IP54 230-240-V 3A jet pump; Automatic discharge valve; Equipotential connection; 2 years guarantee against manufacture defects. Available in chromed.

6 jets d'eau latéraux orientables en ABS; Bouton poussoir pneumatique de 2 fonctions: on/off circuit de l'eau et le réglage manuel d'accès d'air; Grille d'aspiration ABS; Pompe d'eau 650w 230-240-V 3A; Vidage automatique; Liaison équipotentielle; 2 ans de garantie contre les défauts de fabrication. Disponible en chrome.



PNEUMÁTICO SIMPLES ABS
SIMPLE PNEUMATIC ABS
PNEUMATIQUE SIMPLE ABS



6 injetores de água laterais orientáveis em ABS; Comando pneumático de 2 funções: on/off, massagem de água e regulação manual de caudal (mistura de ar); Crivo de sucção ABS; Motor 650w IP54 230-240-V 3A; Válvula de descarga automática; Quadro controlo pneumático com sensor nível de água; Ligação equipotencial; Interruptor diferencial monofásico proteção 25A/30mA - 240V - 50Hz; 2 anos de garantia contra defeitos de fabrico. Disponível em cromado.

6 lateral swivelling water jets in ABS; Pneumatic press button control , 2 functions: on/off water massage and manual air control; Suction strainer in ABS; 650w IP54 230-240-V 3A jet pump; Automatic discharge valve; Pneumatic control panel with water level sensor; Equipotential connection; Residual current operator circuit breaker (RCCB) 25A/30mA - 240V - 50Hz; 2 years guarantee against manufacture defects. Available in chromed.

6 jets d'eau latéraux orientables en ABS; Bouton poussoir pneumatique; 2 fonctions: on/off, massage de l'eau et le réglage manuel d'accès d'air; Grille d'aspiration ABS; Pompe d'eau 650w 230-240-V 3A; Vidage automatique; Commande pneumatique avec sensor de niveau d'eau; Liaison équipotentielle; Disjoncteur différentiel monophasique protection 25A/30mA - 240V - 50Hz; 2 ans de garantie contre les défauts de fabrication. Disponible en chrome.





PNEUMÁTICO DUPLO ABS
DOUBLE PNEUMATIC ABS
PNEUMATIQUE DOBLE ABS



6 injetores de água laterais orientáveis em ABS; 10 injetores de ar em ABS; Comando pneumático 2 funções: on/off massagem de água e regulação manual de caudal (mistura de ar); Comando pneumático on/off massagem de ar; Crivo de sucção ABS; Motor 650w IP54 230-240-V 3A/ 800W IP54 230-240-V 3A (com micros); Compressor 830W IPX5 230-240-V 4.2A com aquecimento; Válvula de descarga automática com dreno; Quadro controlo pneumático com sensor nível de água; Ligação equipotencial; Interruptor diferencial monofásico proteção 25A/30mA - 240V - 50Hz; 2 anos de garantia contra defeitos de fabrico. Disponível em cromado.

6 lateral swivelling water jets in ABS; 10 air jets in ABS; Pneumatic press button control 2 functions: on/off water massage and manual air control; Suction strainer in ABS; 650w IP54 230-240-V 3A jet pump or 800w IP54 230-240-V 3A jet pump (with micros); 830W IPX5 230-240-V 4.2A blower with heating; Automatic discharge valve with drain; Pneumatic control panel with water level sensor; Equipotential connection; Residual current operator circuit breaker (RCCB) 25A/30mA - 240V - 50Hz; 2 years guarantee against manufacture defects. Available in chromed.

6 jets d'eau latéraux orientables en ABS; 10 jets d'air; Bouton-poussoir pneumatique de 2 fonctions: on/off massage de l'eau et le réglage manuel d'accès d'air; Bouton-poussoir pneumatique on/off circuit d'air; Grille d'aspiration ABS; Pompe d'eau 650w 230-240-V 3A ou 800w IP54 230-240-V 3A (avec micros); Ventilateur 830W IPX5 230-240-V 4.2A avec réchauffeur; Vidage automatique avec drain; Tableau de commande pneumatique avec capteur de niveau d'eau; Liaison équipotentielle; Disjoncteur différentiel monophasique protection 25A/30mA - 240V - 50Hz; 2 ans de garantie contre les défauts de fabrication. Disponible en chrome.



ELETRÓNICO SIMPLES ABS
SIMPLE ELECTRONIC ABS
ELECTRONIQUE SIMPLE ABS



6 injetores de água laterais orientáveis em ABS; Comando digital de 3 funções: on/off massagem de água, intermitência automática de água e regulação manual de caudal (mistura de ar); Crivo de sucção ABS; Motor 650w IP54 230-240-V 3A / 800W IP54 230-240-V 3A (com micros); Válvula de descarga automática; Quadro controlo eletrónico KOLLER SYSTEM; Sensor nível de água; Ligação equipotencial; Interruptor diferencial monofásico proteção 25A/30mA - 240V - 50Hz; 2 anos de garantia contra defeitos de fabrico. Disponível em cromado.

6 lateral swivelling water jets in ABS; Electronic control 3 functions: on/off water massage, automatic water interval and manual air control; Suction strainer in ABS; 650w IP54 230-240-V 3A jet pump or 800W IP54 230-240-V 3A jet pump (with micros); Automatic discharge valve; KOLLER SYSTEM electronic control panel; Water level sensor; Equipotential connection; Residual current operator circuit breaker (RCCB) 25A/30mA - 240V - 50Hz; 2 years guarantee against manufacture defects. Available in chromed.

6 jets d'eau latéraux orientables en ABS; Interrupteur électronique de 3 fonctions: on/off massage de l'eau, automatique intermittente de l'eau et le réglage manuel d'accès d'air; Grille d'aspiration ABS; Pompe d'eau 650w 230-240-V 3A ou 800w IP54 230-240-V 3A (avec micros); Vidage automatique; Commande électronique KOLLER SYSTEM; Capteur de niveau d'eau; Disjoncteur différentiel monophasique protection 25A/30mA - 240V - 50Hz; 2 ans de garantie contre les défauts de fabrication. Disponible en chrome.





SISTEMAS DE HIDROMASSAGEM p.219/p.263

WHIRLPOOL SYSTEMS
SYSTÈMES DE HYDROMASSAGE

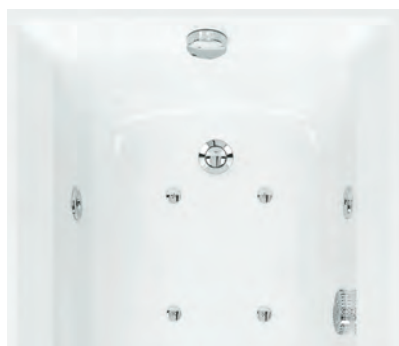

ELETRÔNICO DUPLO ABS
DOUBLE ELECTRONIC ABS
ELECTRONIQUE DOBLE ABS



6 injetores de água laterais orientáveis em ABS; 10 injetores de ar em ABS; Comando eletrônico de 4 funções: on/off massagem de água e ar, intermitência automática de água, variação automática de intensidade do ar; Regulador manual de caudal (mistura de ar); Crivo de sucção ABS; Motor 650W IP54 230-240-V 3A ou 800W IP54 230-240-V 3A (com micros); Compressor 830W IPX5 230-240-V 4.2A com aquecimento; Válvula de descarga automática com dreno; Quadro controlo eletrónico KOLLER SYSTEM; Sensor nível de água eletrônico; Ligação equipotencial; Interruptor diferencial monofásico proteção 24A/30mA - 240V - 50 Hz; 2 anos de garantia contra defeitos de fabrico.
Disponível em cromado.

6 lateral swivelling water jets ABS; 10 air jets in ABS; Electronic control 4 functions: on/off and air massage, automatic water interval, automatic variation of air intensity; Manual air control; Suction strainer in ABS; 650W IP54 230-240-V 3A jet pump or 800W IP54 230-240-V 3A jet pump (with micros); 830W IPX5 230-240-V 4.2A blower with heating; Automatic discharge valve with drain; KOLLER SYSTEM electronic control panel; Electronic water level sensor; Equipotential connexion; Residual current operator circuit breaker (RCCB) 25A/30mA - 240V - 50Hz; 2 years guarantee against manufacture defects.
Available in chromed.

6 jets d'eau latéraux orientables en ABS; 10 jets d'air en ABS; Panneaux de commande électronique de 4 fonctions: on/off massage d'eau et d'air, automatique de l'intermittence de l'eau et variation automatique de l'intensité de l'air; Réglage manuel d'accès d'air; Grille d'aspiration ABS; Pompe d'eau 650W IP54 230-240-V 3A ou 800W IP54 230-240-V 3A (avec micros); Ventilateur 830W IPX5 230-240-V 4.2A avec réchauffeur; Vidage automatique avec drain; Commande électronique KOLLER SYSTEM; Électronique capteur de niveau d'eau; Liaison équipotentielle; Disjoncteur différentiel monophasique protection 25A/30mA - 240V - 50Hz; 2 ans de garantie contre les défauts de fabrication.
Disponible en chrome.



ELETRÔNICO KOMBI ABS
KOMBI ELECTRONIC ABS
ELECTRONIQUE KOMBI ABS



6 injetores de água laterais orientáveis em ABS; 10 injetores inferiores em ABS; Comando eletrônico de 3 funções: on/off massagem de água, intermitência automática de água e regulação manual de caudal (mistura de ar); Inversor 2 vias com 3 posições: massagem lateral, massagem inferior ou funcionamento de ambas em simultâneo; Crivo de sucção ABS; Motor 650w IP54 230-240-V 3A ou 800W IP54 230-240-V 3A (com micros); Válvula de descarga automática com dreno; Quadro controlo eletrónico KOLLER SYSTEM; Sensor nível de água eletrônico; Ligação equipotencial; Interruptor diferencial monofásico proteção 25A/30mA - 240V - 50Hz; 2 anos de garantia contra defeitos de fabrico.
Disponível em cromado.

6 lateral swivelling jets in ABS; 10 lower jets in ABS; Electronic control 3 functions: on/off water massage, automatic water interval and manual air control, 2 way inverter with 3 positions: side massage, lower massage or simultaneous operation of both; Suction strainer in ABS; 650w IP54 230-240-V 3A jet pump or 800W IP54 230-240-V 3A jet pump (with micros); Automatic discharge valve with drain; KOLLER SYSTEM Electronic control panel; Electronic water level sensor; Equipotential connection; Residual current operator circuit breaker (RCCB) 25A/30mA - 240V - 50Hz; 2 years guarantee against manufacture defects.
Available in chromed.

6 jets d'eau latéraux orientables en ABS; 10 inférieure jets en ABS; Panneaux de commande électronique 3 fonctions: on/off massage d'eau et d'air et réglage manuel d'accès d'air; Inverseur à 2 voies avec 3 positions: massage latéraux, massage inférieure ou fonctionnement simultané des deux; Grille d'aspiration ABS; Pompe d'eau 650w 230-240-V 3A ou 800W IP54 230-240-V 3A (avec micros); Vidage automatique avec drain; Commande électronique KOLLER SYSTEM; Électronique capteur de niveau d'eau; Liaison équipotentielle; Disjoncteur différentiel monophasique protection 25A/30mA - 240V - 50Hz; 2 ans de garantie contre les défauts de fabrication.
Disponible en chrome.





ELETRÔNICO DUPLO FLAT LATÃO
DOUBLE ELECTRONIC FLAT BRASS
ELECTRONIQUE DOBLE FLAT LAITON



COMFORT LATÃO
COMFORT BRASS
CONFORT LAITON



6 injetores de água laterais orientáveis flat em latão; 10 injetores de ar flat em latão; Comando eletrônico flat 4 funções: on/off massagem de água e ar, seleção +/- intensidade massagem de água e ar, intermitência automática da massagem de água, variação automática de intensidade da massagem de ar; Regulador manual de caudal quadrado (mistura de ar); Crivo de sucção flat; Motor 650w IP54 230-240-V 3A/ 800W IP54 230-240-V 3A (com micros); Compressor 830W IPX5 230-240-V 4.2A com aquecimento; Válvula de descarga automática flat com dreno; Quadro controlo eletrónico KOLLER SYSTEM; Sensor nível de água eletrônico; Ligação equipotencial; Interruptor diferencial monofásico proteção 25A/30mA - 240V - 50Hz; 2 anos de garantia contra defeitos de fabrico.
Disponível em cromado.

6 lateral brass swivelling water jets flat; 10 brass air jets flat; Electronic control 4 functions: on/off water and air massage, +/- water and air intensity, automatic water interval, automatic variation of air intensity; Square manual air control; Suction strainer; 650w IP54 230-240-V 3A jet pump or 800w IP54 230-240-V 3A jet pump (with micros); 830W IPX5 230-240-V 4.2A blower with heating; Automatic discharge valve flat with drain; KOLLER SYSTEM electronic control panel; Electronic water level sensor; Equipotential connection; Residual current operator circuit breaker (RCCB) 25A/30mA - 240V - 50Hz; 2 years guarantee against manufacture defects.
Available in chromed.

6 jets d'eau latéraux orientables flat en laiton; 10 jets d'air flat en laiton; Panneaux de commande électronique de 4 fonctions: on/off massage d'eau et d'aire, +/- intensité de l'eau et de l'air, automatique intermitente de l'eau et variation automatique de l'intensité de l'air; Réglage manuel d'accès d'air carré; Grille d'aspiration laiton flat; Pompe d'eau 650w 230-240-V 3A ou 800w IP54 230-240-V 3A (avec micros); Ventilateur 830W IPX5 230-240-V 4.2A avec réchauffeur; Vidage automatique flat avec drain; Commande électronique KOLLER SYSTEM; Électronique capteur de niveau d'eau; Liaison équipotentielle; Disjoncteur différentiel monophasique protection 25A/30mA - 240V - 50Hz; 2 ans de garantie contre les défauts de fabrication.
Disponível en chrome.



6 injetores de água laterais orientáveis flat em latão; 10 injetores de ar flat em latão; Comando eletrônico CONFORT multifunções vertical: on/off massagem de água, +/- intensidade, massagem de água, on/off intermitência automática de água, on/off variação automática de intensidade de água, on/off massagem de ar, +/- intensidade de ar, on/off intermitência automática de ar, on/off variação automática da intensidade de ar, on/off lâmpada de iodo, on/off intermitência lâmpada de iodo, on/off desinfecção automática, on/off resistência aquecimento, +/- temperatura água (35°C a 45°C); Visor digital de indicação de temperatura da água; Sistema de desinfecção automática; Lâmpada de iodo flat; Crivo de sucção flat; Motor 700w IP55 230-240-V 2.8A ou 1100W IPX5 230-240-V 4.8A (com micros); Compressor 830W IPX5 230-240-V 4.8A com aquecimento; Resistência aquecimento de água 1500W; Válvula de descarga automática com dreno flat; Quadro controlo eletrónico KOLLER SYSTEM; Sensor nível de água eletrônico; Ligação equipotencial; Interruptor diferencial monofásico proteção 25A/30mA - 240V - 50Hz; 2 anos de garantia contra defeitos de fabrico.
Disponível em cromado.

6 lateral brass swivelling water jets flat; 10 brass air jets flat; Electronic COMFORT multifunctional vertical control: on/off water massage, +/- water intensity, on/off automatic water interval, digital water intensity control, on/off air massage, +/- air intensity, on/off automatic air interval, digital air intensity control, on/off spa light, on/off spa light interval, on/off disinfection, on/off heating, +/- water temperature (35°C to 45°C); Digital display for water temperature; Automatic disinfection system; Flat spa light; Suction strainer; 700w IP55 230-240-V 2.8A jet pump or 1100W IPX5 230-240-V 4.4A jet pump (with micros); 830W IPX5 230-240-V 4.8A blower with heating; 1500W water heating; Automatic discharge valve flat with drain; KOLLER SYSTEM electronic control panel; Electronic water level sensor; Equipotential connection; Residual current operator circuit breaker (RCCB) 25A/30mA - 240V - 50Hz; 2 years guarantee against manufacture defects.
Available in chromed.

6 jets d'eau latéraux orientables flat en laiton; 10 jets d'air flat en laiton; Panneaux de commande électronique verticale multifonction CONFORT: on/off massage d'eau, +/- intensité de l'eau, on/off automatique intermitente de l'eau, on/off variation automatique d'intensité de l'eau, on/off massage d'aire, +/- intensité de l'aire, on/off automatique intermitente de l'aire, on/off variation automatique d'intensité de l'aire, on/off lampe à iode, on/off lampe à iode intermitente, on/off désinfection automatique, on/off réchauffeur, +/- température de l'eau (35°C a 45°C); Écran d'indication de la température de l'eau; Système de désinfection automatique; Lampe à iode chrome, blanc ou doré; Grille d'aspiration laiton flat; Pompe d'eau 700W IP55 230-240-V 2.8A ou 1100W IPX5 230-240-V 4.4A (avec micros); Ventilateur 830W IPX5 230-240-V 4.8A avec réchauffeur; Réchauffeur 1500W; Vidage automatique flat avec drain; Commande électronique KOLLER SYSTEM; Électronique capteur de niveau d'eau; Liaison équipotentielle; Disjoncteur différentiel monophasique protection 25A/30mA - 240V - 50Hz; 2 ans de garantie contre les défauts de fabrication.
Disponível en chrome.



HIDROMASSAGEM p.219/p.263

WHIRLPOOL
HYDROMASSAGE

JATOS DE ÁGUA LATERAIS

LATERAL WATER JETS
JETS D'EAU LATÉRAUX



JATOS DE AR INFERIORES

LOWER AIR JETS
JETS D'AIR INFÉRIEURES



SEGURANÇA

Conforme as normas CE, a proteção elétrica é feita por intermédio de um dispositivo de corrente residual (DDR) tendo uma corrente nominal não excedendo os 30mA, a sua instalação deve ficar no quadro geral da habitação, com uma linha direta à banheira de hidromassagem.

SAFETY

According to the CE norms, the electric protection is made through a residual current operator circuit breaker (RCCB) device where the nominal current doesn't exceed the 30mA, the installation should be made in the electric panel boarder of the house, with a direct line to the whirlpool.

SÉCURITÉ

Conforme les normes CE, la protection électrique se fait à travers d'un dispositif de courant résiduel (DCR) avec un courant nominal de 30mM, son installation doit être dans le cabinet électrique de la maison, avec une ligne directe pour la baignoire de hydromassage.

GARANTIA

Todas as banheiras são testadas rigorosamente garantindo a sua perfeita segurança elétrica e o seu bom funcionamento. Os equipamentos de hidromassagem ASD têm uma garantia de 2 anos e dispõem de serviço de assistência técnica em todo o país.

Serviço de Apoio ao cliente ASD: 808 208 088

WARRANTY

All bathtubs are tested guaranteeing their strictly perfect electric safety and it's well function. The whirlpool equipments ASD have 2 years warranty and technical support service in all country.

ASD customer service: 808 208 088

GARANTIE

Toutes les baignoires sont rigoureusement testés pour garantir sa parfaite sécurité électrique et leur bon fonctionnement. ASD hydro matériel est garant pour 2 ans et offre de services techniques à travers le pays.

Service après-vente ASD: 808 208 088



SISTEMA DE DESINFEÇÃO
DESINFECTATION SYSTEM
SYSTÈME DE DESINFECTION



MICROJETOS
MICRO JETS
MICROJETS



OUTRAS OPÇÕES
Aromaterapia (limão, camomila, lavanda, pinho, laranja, etc.);
Compressor com fabrico de ozono;
Comando à distância;
Líquido de limpeza para sistema de desinfeção;
Válvula de enchimento com descarga automática para banheiras de hidromassagem.

LÂMPADA DE IODO
SPA LIGHT
LAMPE À IODE



JATOS DE PESCOÇO
NECK JETS
JETS DE COU



OTHER OPTIONS
Aromatherapy (lemon, chamomile, lavender, pine, orange, etc.);
Air blower with ozone;
Remote control;
Cleaner liquid for disinfection system;
Bath pop-up waste with overflow water outlet spout for hydromassage bathtub.

D'AUTRES OPTIONS
Aromathérapie (citron, camomille, lavande, pin, orange, etc.);
Compresseur d'ozone;
Télécommande;
Liquide de nettoyage pour le système de désinfection;
Vidage d'empliszez avec décharge automatique pour les baignoires de hidromassage.



CROMOTERAPIA EM BANHEIRAS DE HIDROMASSAGEM

WHIRLPOOLS CHROMOTHERAPY | CHROMOTHÉRAPIE POUR BAIGNOIRES DE HIDROMASSAGE

A cromoterapia é um tratamento terapêutico alternativo ou complementar que usa a natureza da cor e da sua vibração para estabelecer o equilíbrio biológico e a harmonia das faculdades mentais e dos estados emocionais, restaurando o equilíbrio físico-energético em áreas do corpo humano atingidas por alguma disfunção. A cromoterapia usa as cores do espectro solar (branco, vermelho, amarelo, verde, ciano, violeta e azul).

Chromotherapy is an alternative or complementary treatment, based on the nature and vibration of colour. It is used to establish biological balance, emotional states and mental harmony, restoring physical and energetic balance in certain areas of the human body which have been affected by some kind of dysfunction. Chromotherapy uses the colours of the solar spectrum, which are known to be: white, red, yellow, green, indigo, violet and blue.

Le chromothérapie est un traitement thérapeutique alternatif ou complémentaire qui utilise la nature et la dynamique de la couleur pour établir l'équilibre biologique et l'harmonie des états mentaux et émotionnels, rétablissant l'équilibre énergétique et physique dans les régions du corps touchées par un handicap. La chromothérapie utilise les couleurs du spectre solaire (blanc, rouge, jaune, vert, cyan, violet et bleu).

